

Cryptocurrencies *from technology to economy*



Roger Wattenhofer











Hacker stahlen ETH-Doktoranden Bitcoin für 9 Millionen

Diebstahl Hacker erbeuteten bei einem Mitarbeiter der ETH Zürich 9222 Bitcoin. Heute sind die virtuellen Münzen 9 Millionen Franken wert. Der Fall liegt nun bei der Kantonspolizei.

VON CHRISTIAN BÜTIKOFER 06.12.2013



Cryptocurrencies

▲#	Name	Market Cap	Price	Available Supply	Volume (24h)
1	 Bitcoin	\$ 8,981,243,870	\$ 574.31	15,638,375 BTC	\$ 71,004,500
2	 Ethereum	\$ 1,172,919,101	\$ 14.51	80,853,613 ETH	\$ 9,933,140
3	 Litecoin	\$ 216,171,881	\$ 4.68	46,149,551 LTC	\$ 5,031,230
4	 Ripple	\$ 201,593,968	\$ 0.005782	34,868,679,462 XRP *	\$ 552,597
5	 The DAO	\$ 162,984,082	\$ 0.138973	1,172,775,159 DAO *	\$ 1,502,090
6	 Dash	\$ 51,232,986	\$ 7.87	6,510,786 DASH	\$ 248,316
7	 Lisk	\$ 46,560,900	\$ 0.465609	100,000,000 LSK *	\$ 2,472,480
8	 Dogecoin	\$ 27,584,159	\$ 0.000263	104,686,099,387 DOGE	\$ 506,232
9	 MaidSafeCoin	\$ 25,406,247	\$ 0.056140	452,552,412 MAID *	\$ 421,888
10	 DigixDAO	\$ 20,670,600	\$ 10.34	2,000,000 DGD *	\$ 65,517

What is Bitcoin?



+



+



=





«Satoshi Nakamoto»

Technology

The Bank of Bitcoin



The Bank of Bitcoin



User	Balance
A	2
B	5
C	8

The Bank of Bitcoin

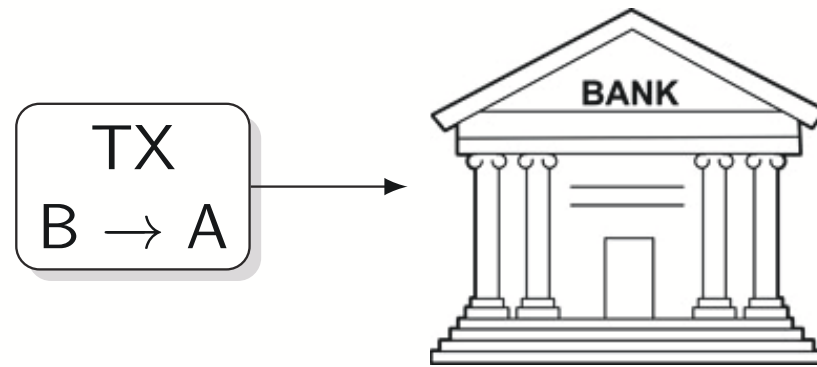

User	Balance
A	2
B	5
C	8

The Bank of Bitcoin

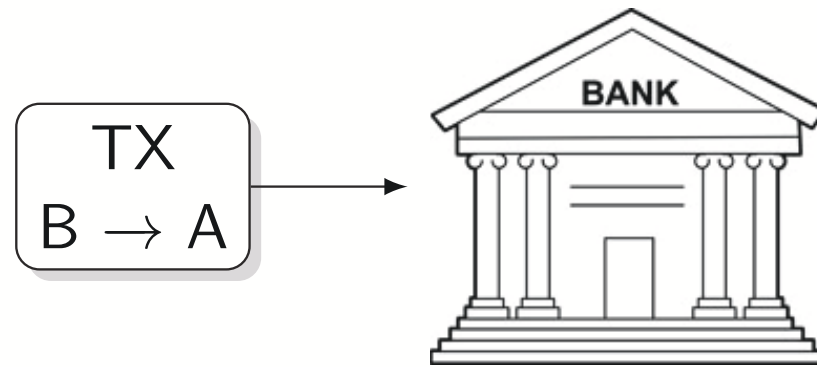

User	Balance
A	24
B	53
C	8

Opening an Account in Bitcoin



Transferring Bitcoins

TX: 41b221

Transferring Bitcoins

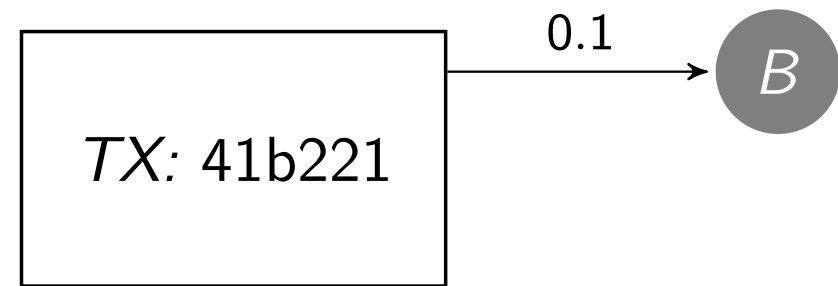

Transferring Bitcoins

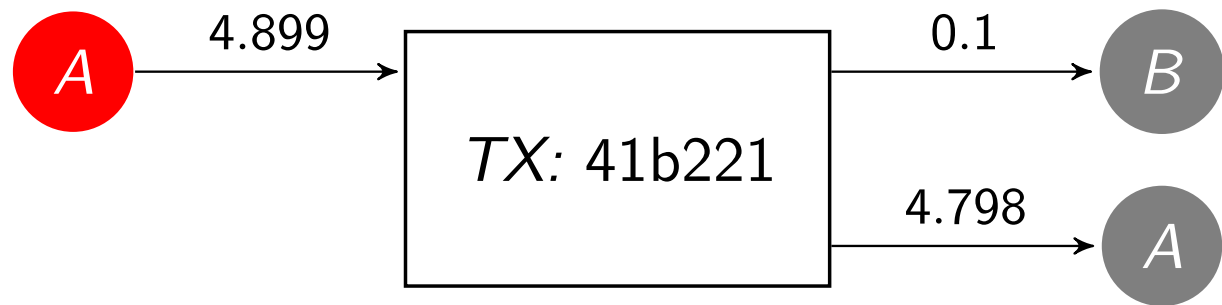

Transferring Bitcoins

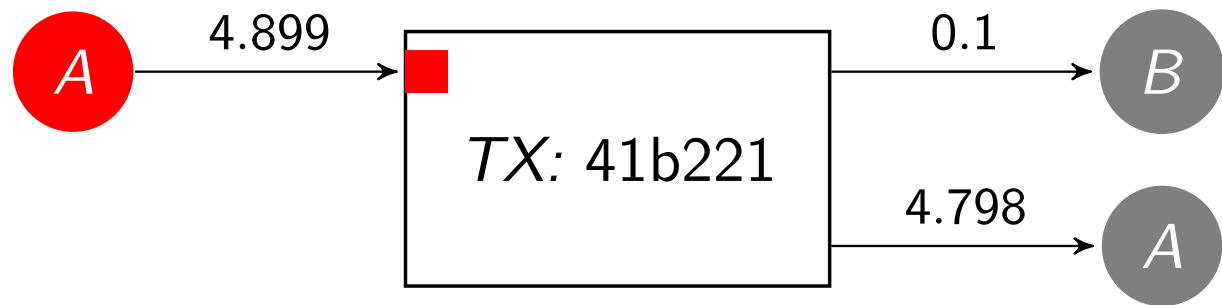

Transferring Bitcoins

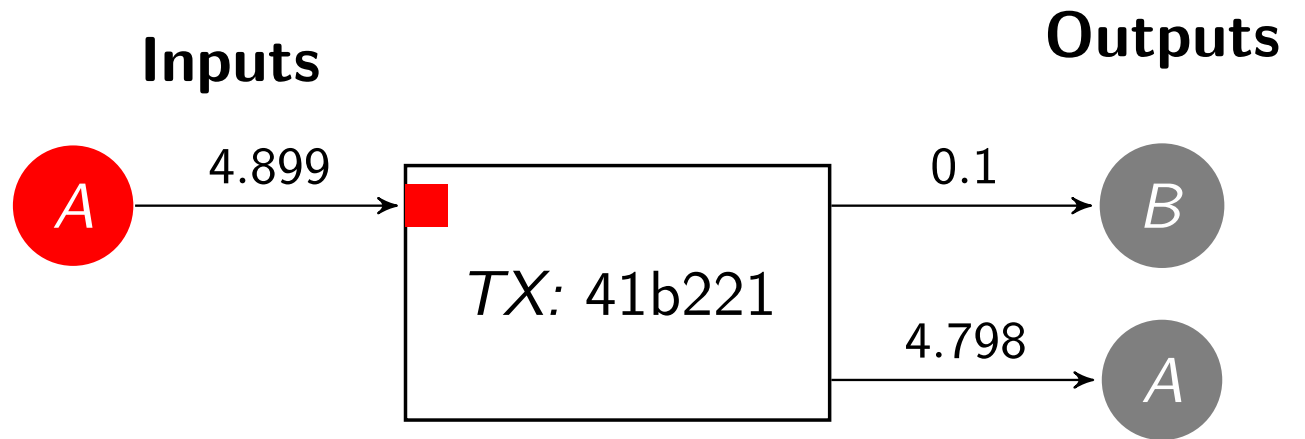

Transferring Bitcoins

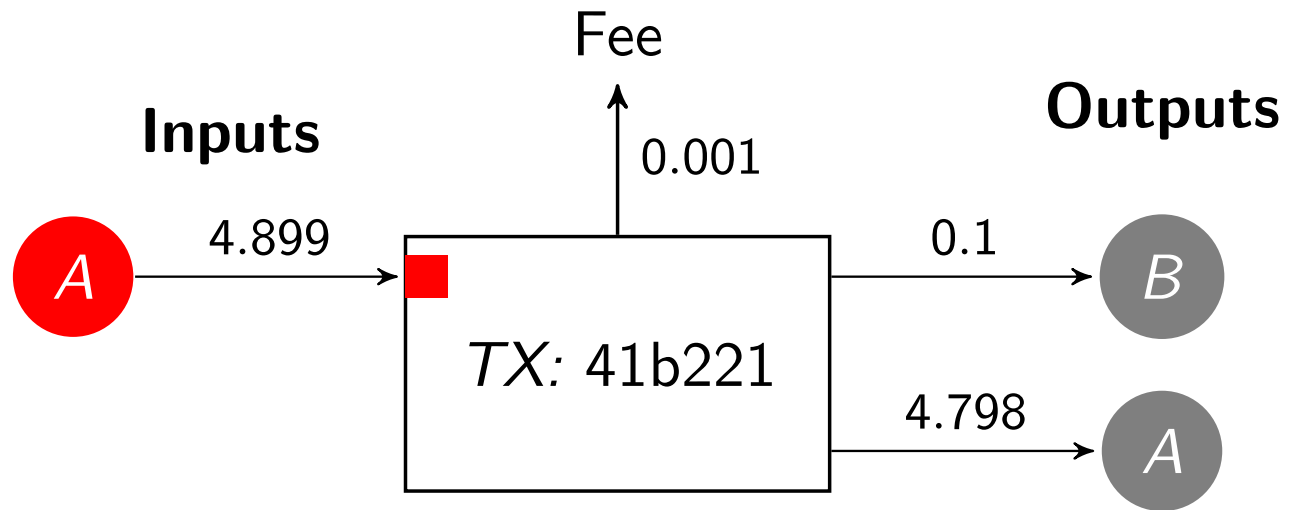

Transferring Bitcoins

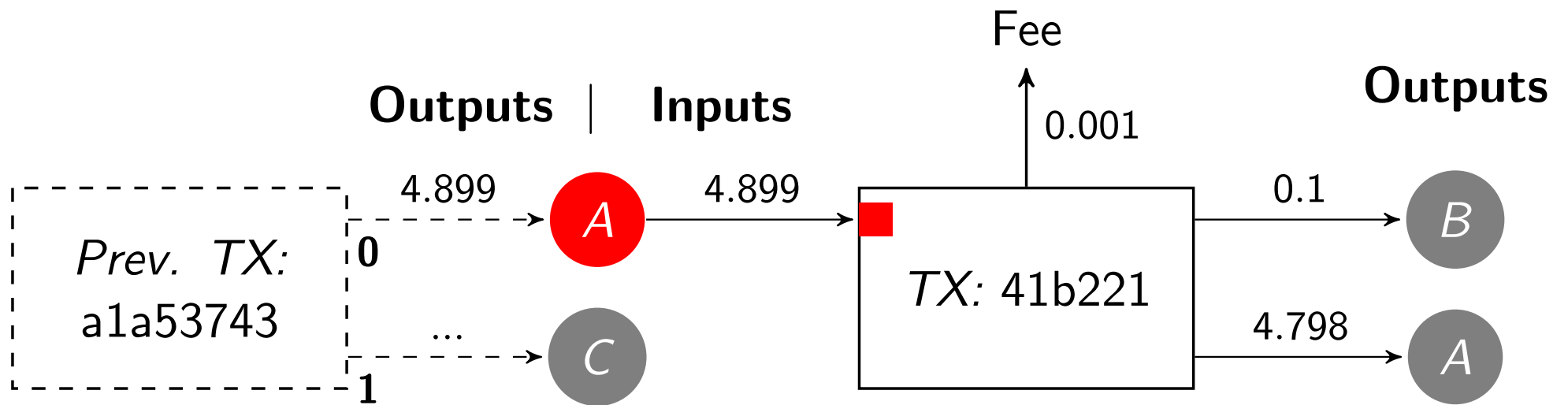

Distributing the Bank

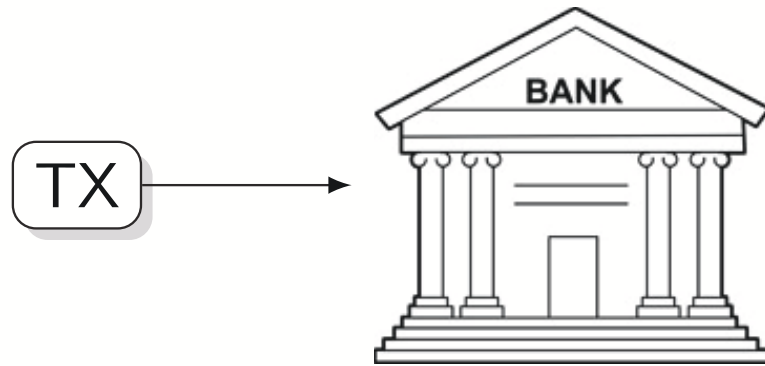

User	Balance
A	2
B	5
C	8

Distributing the Bank

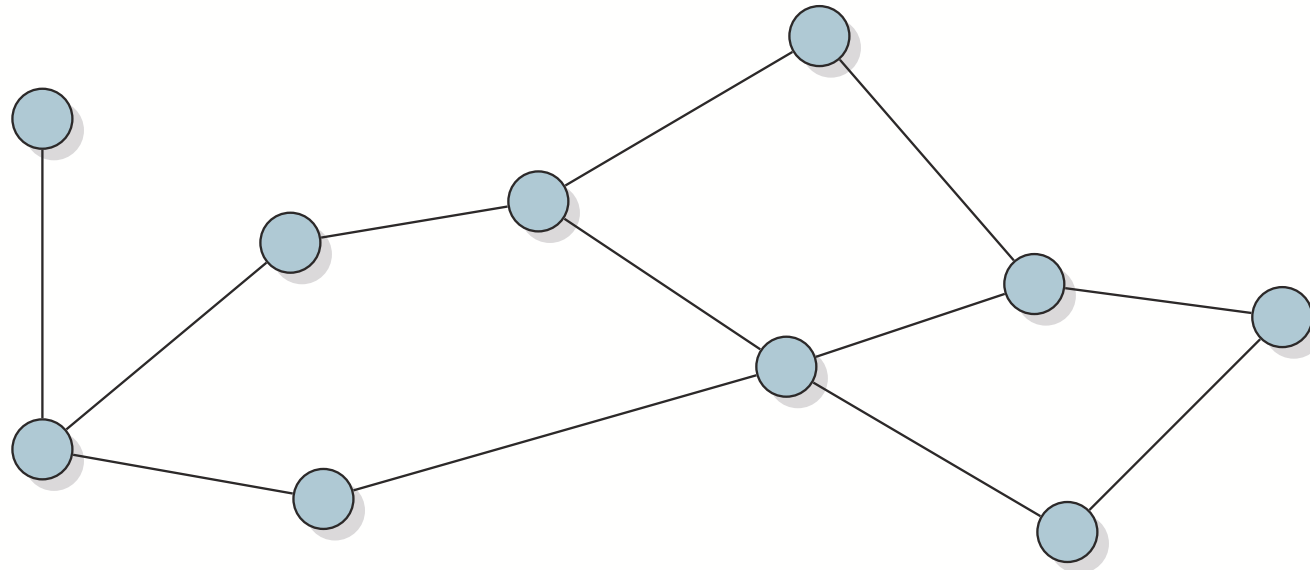

Distributing the Bank

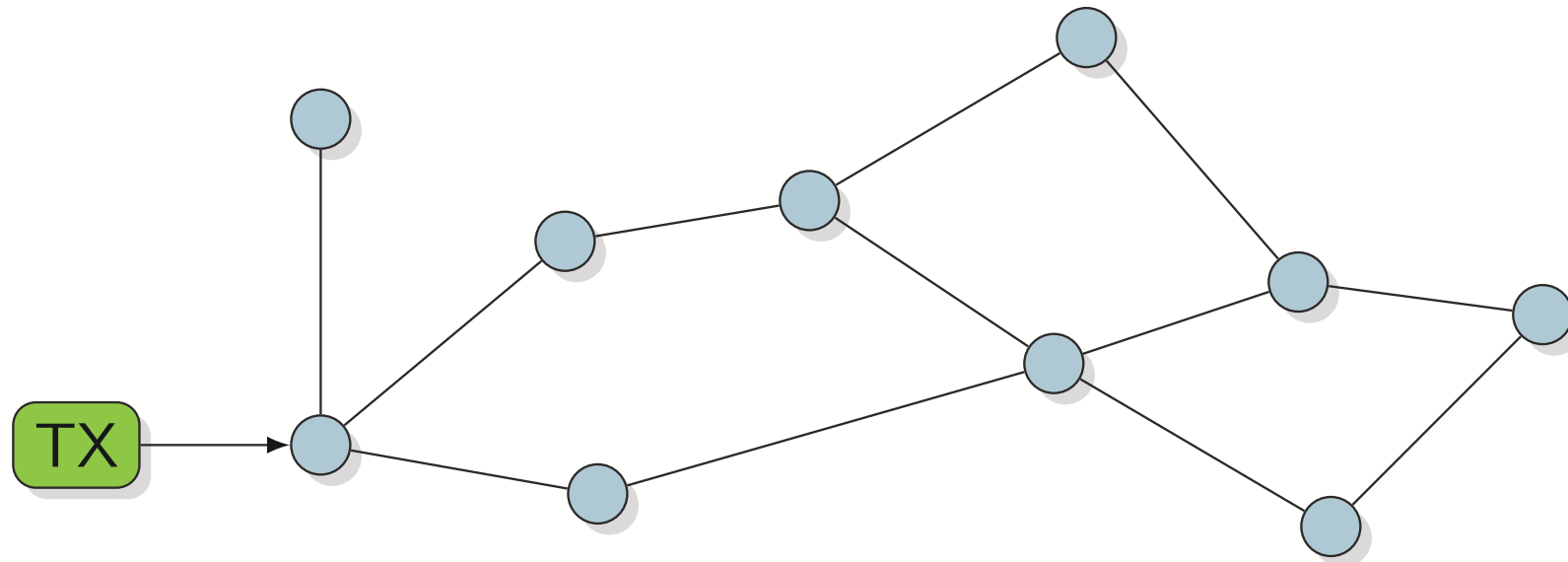

Distributing the Bank

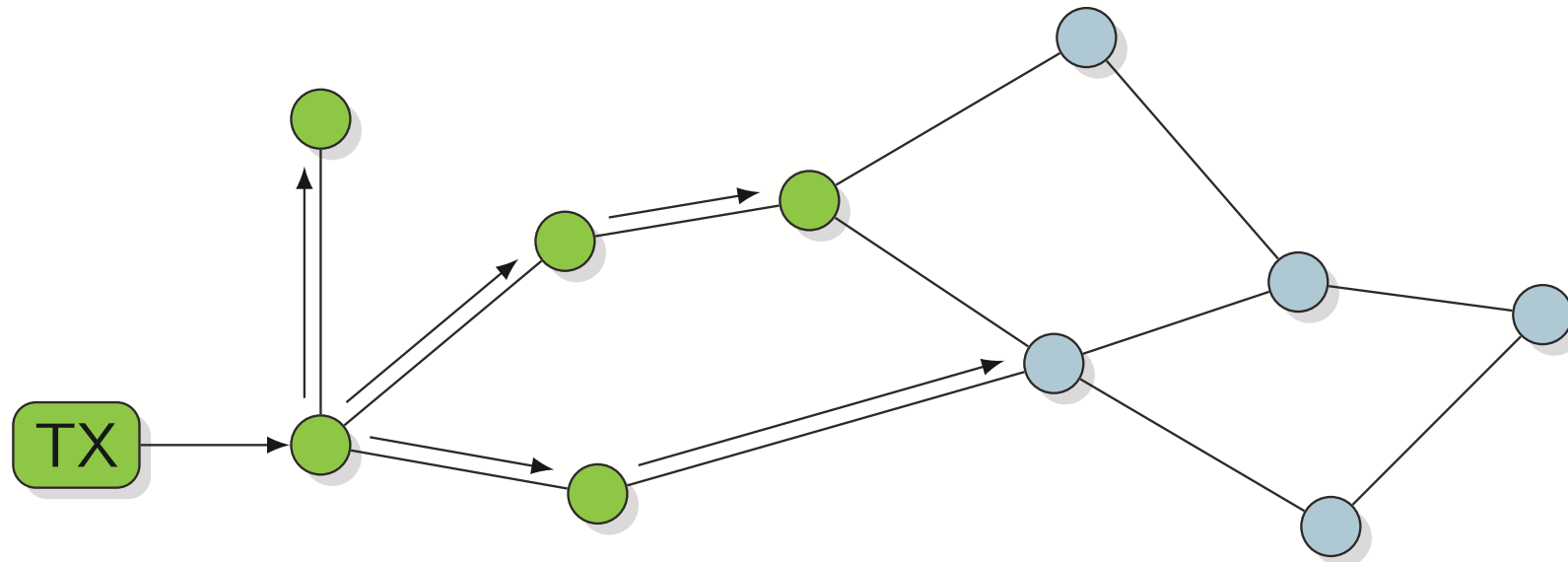

Distributing the Bank

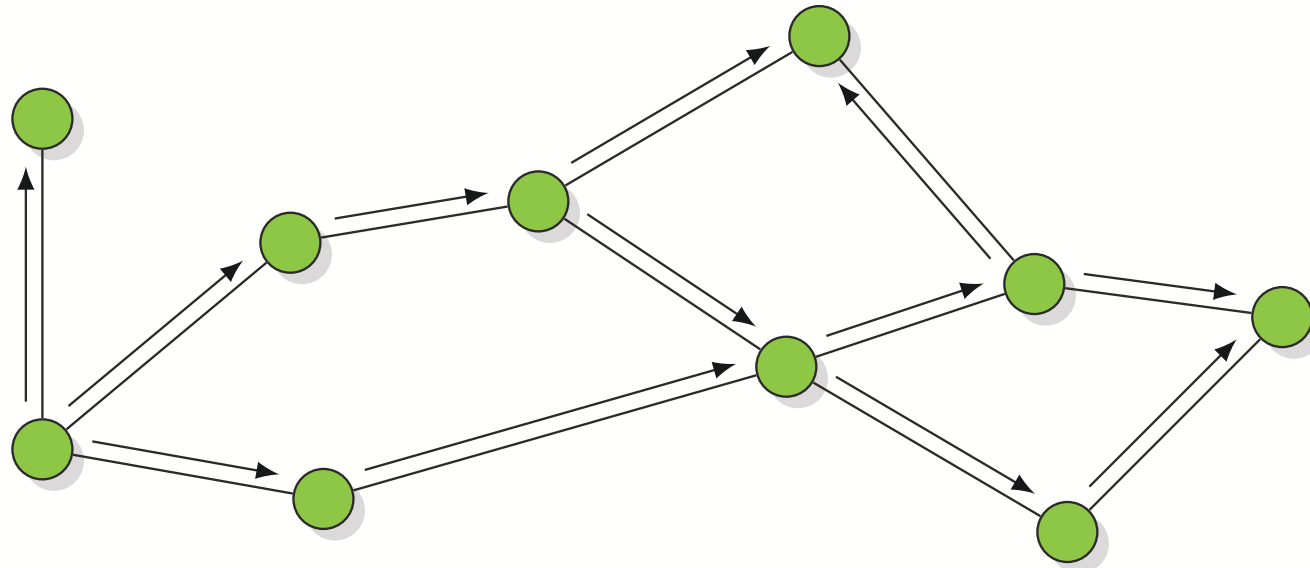

Distributing the Bank

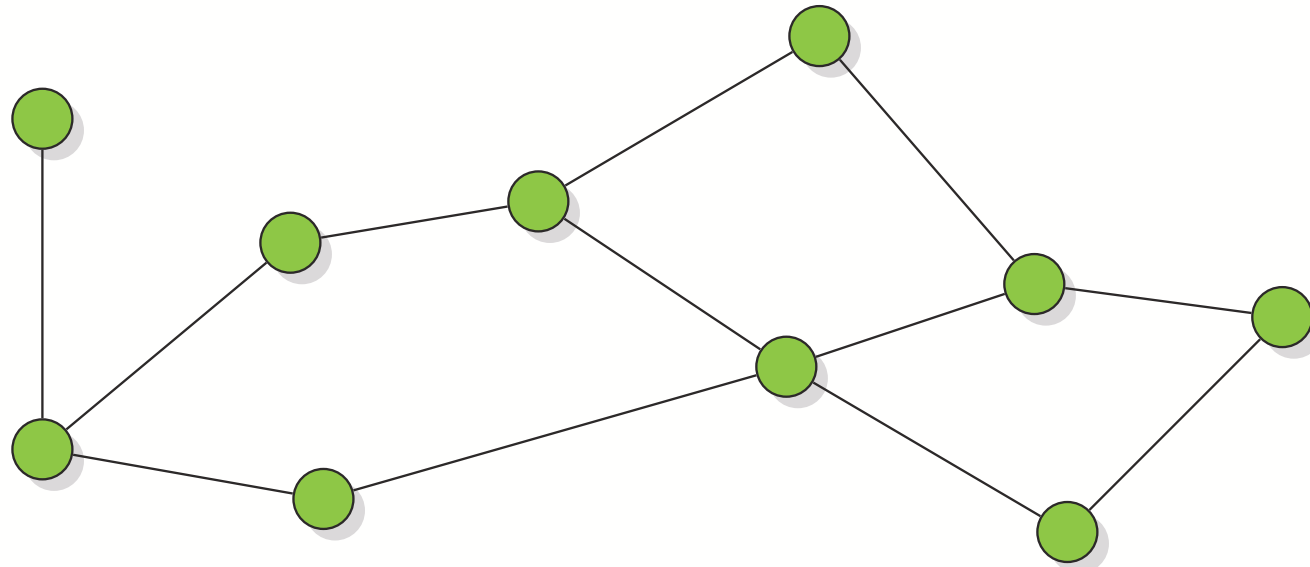

Let's Buy a Snack

[Bamert, Decker, Elsen, W, Welten, 2013]



Doublespending

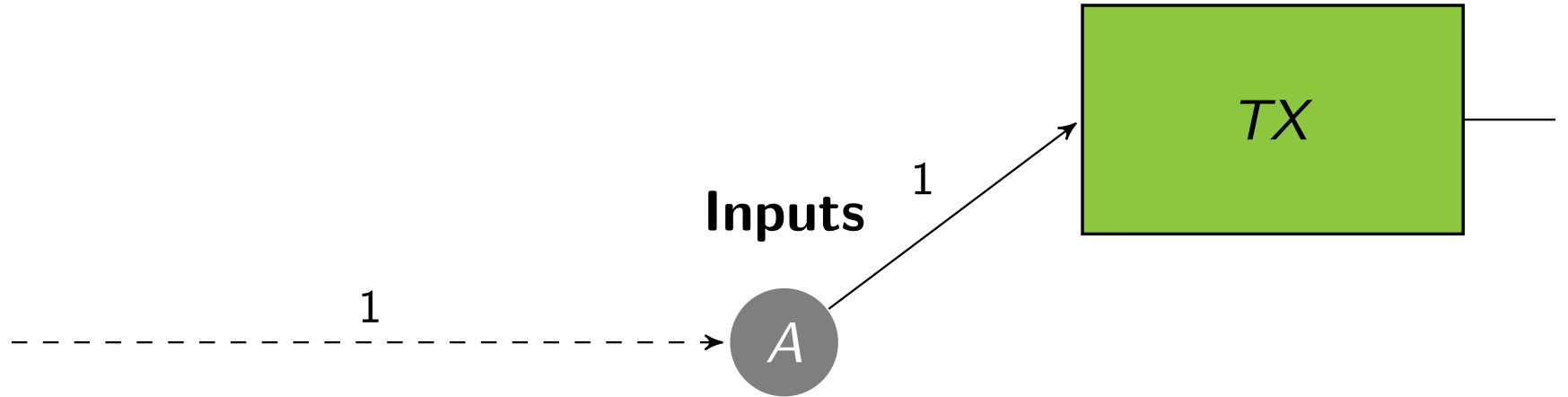

Doublespending

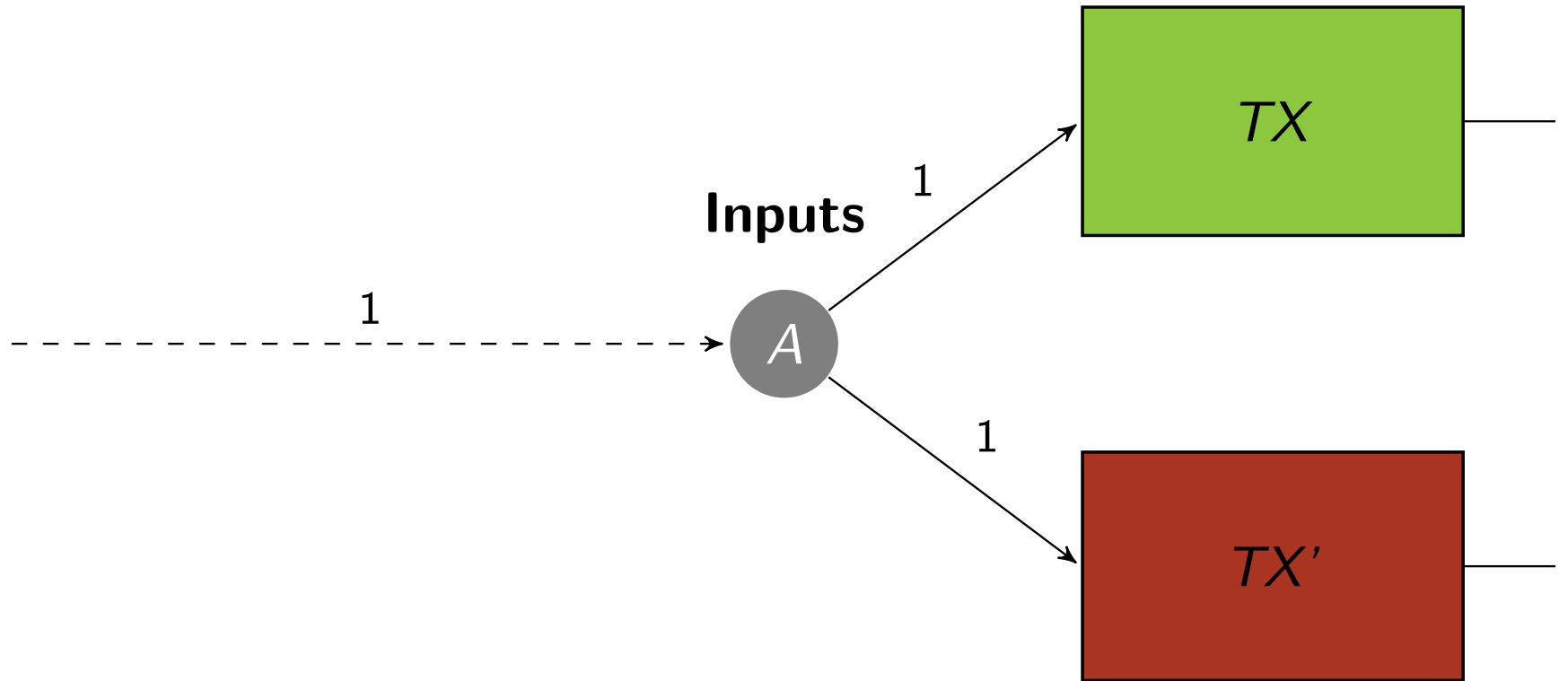

Doublespending

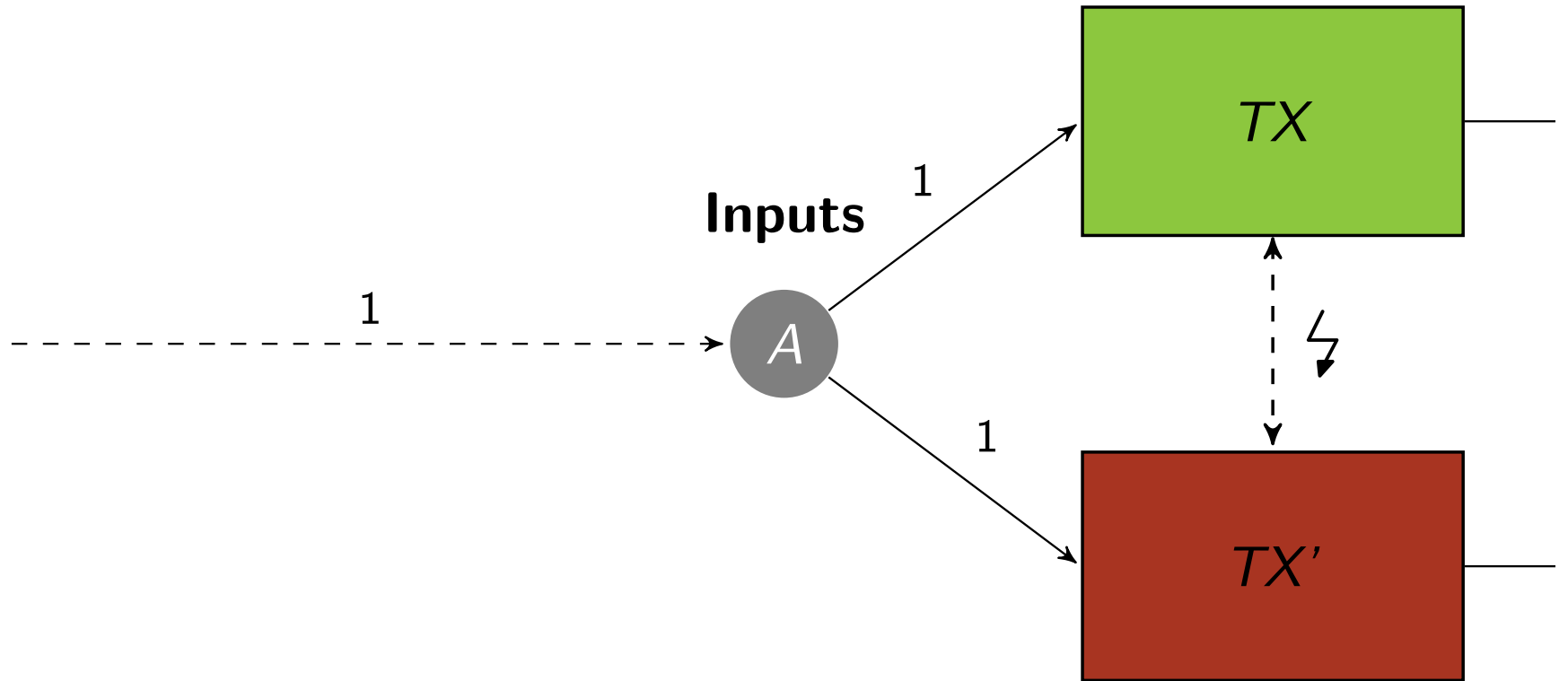

Transaction Conflicts

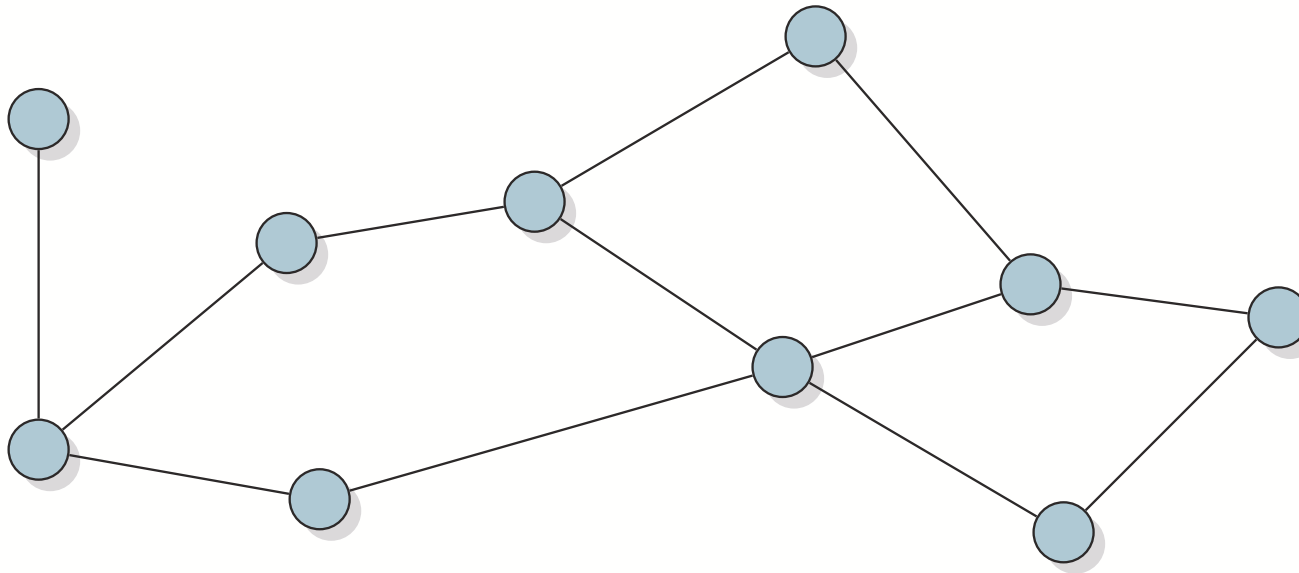

Transaction Conflicts

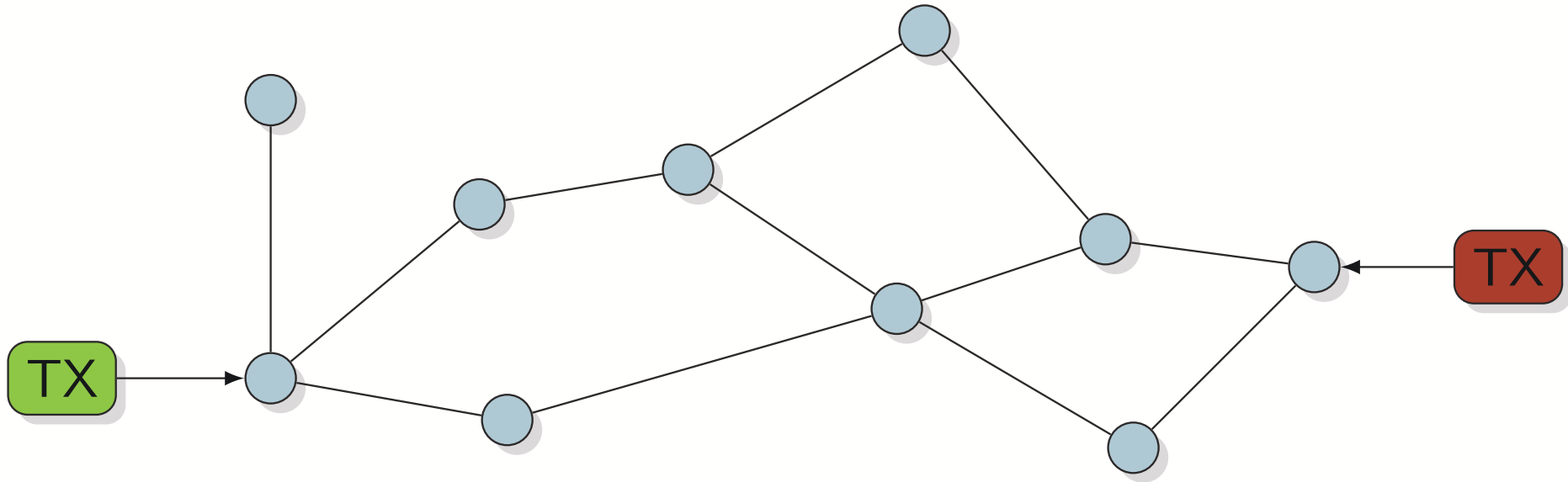

Transaction Conflicts

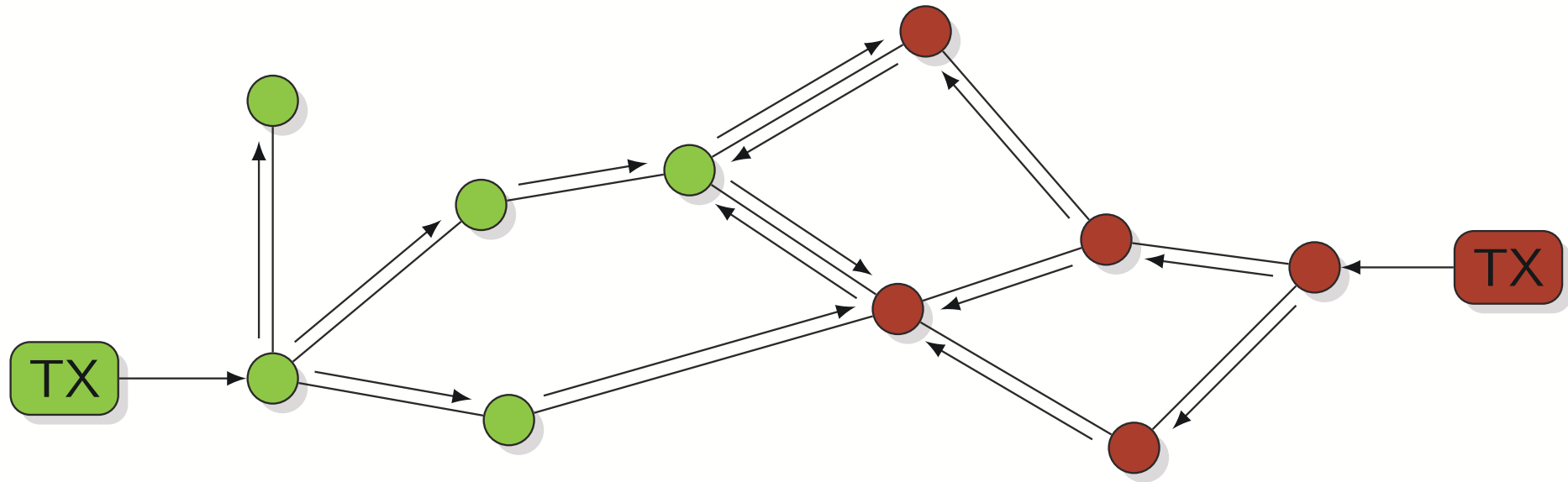

Transaction Conflicts

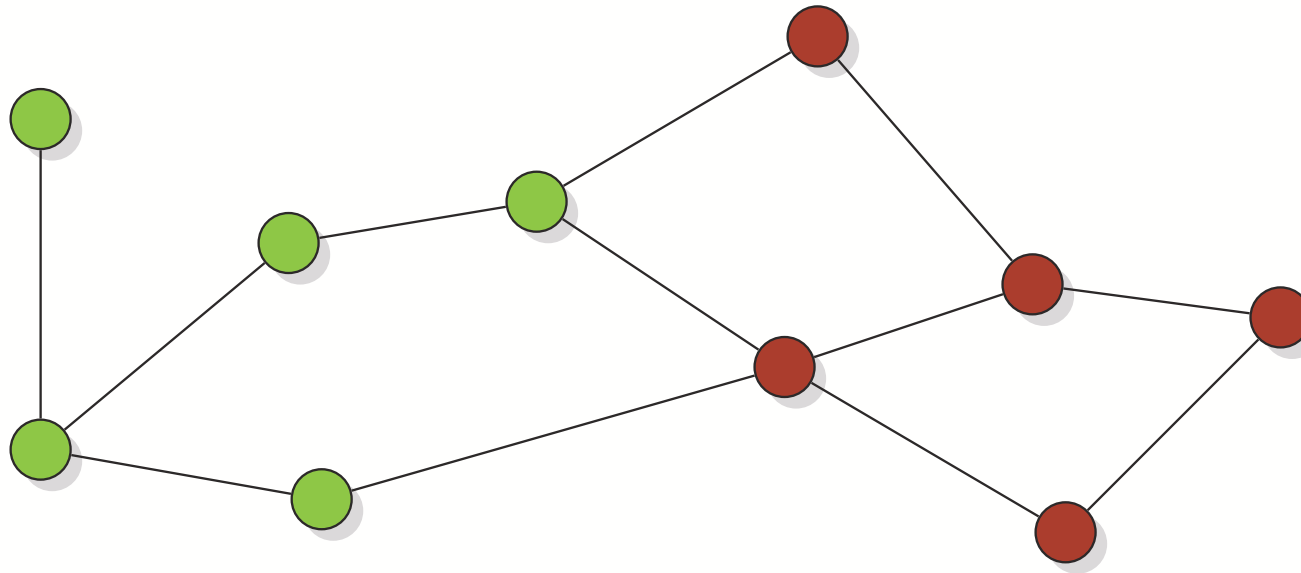

Resolving Conflicts

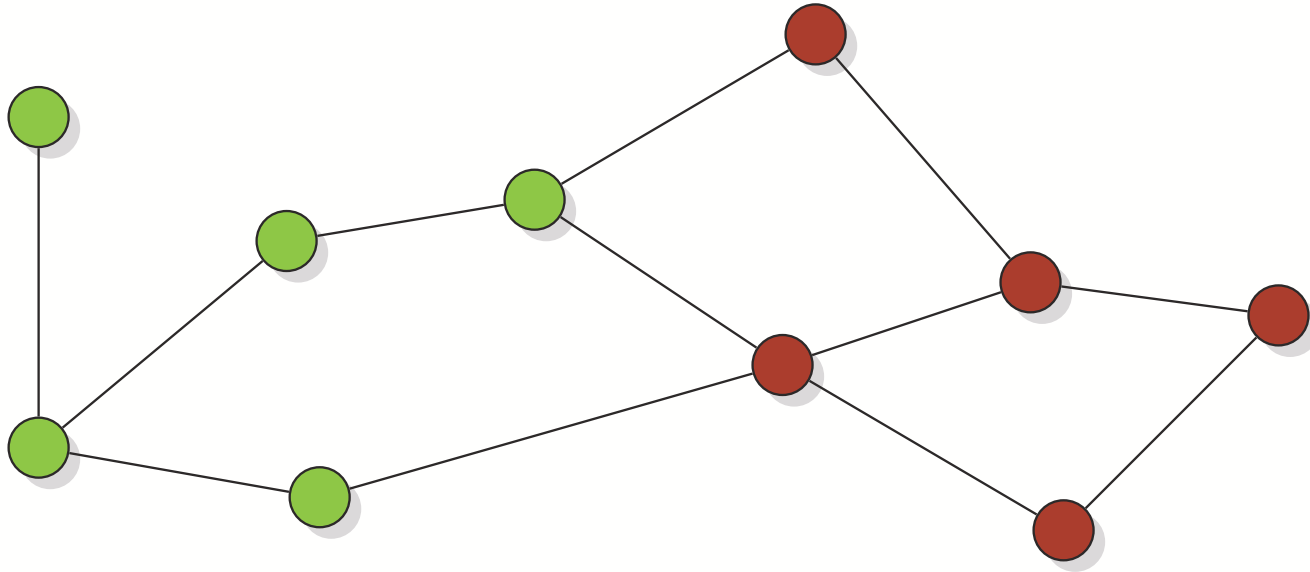

Resolving Conflicts

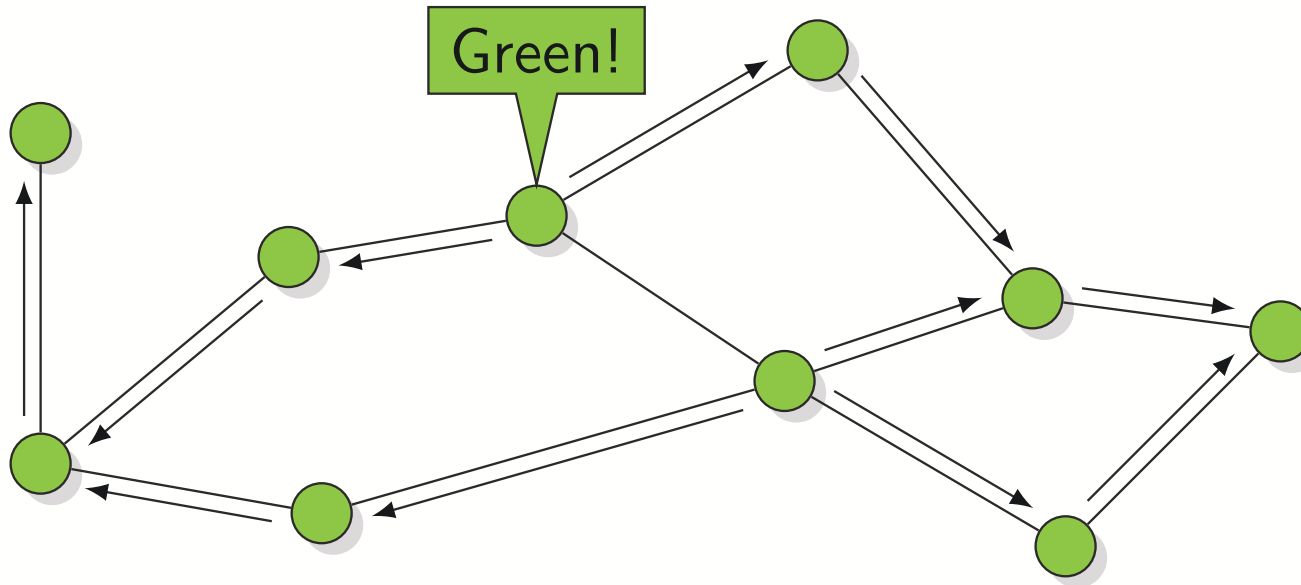

Resolving Conflicts

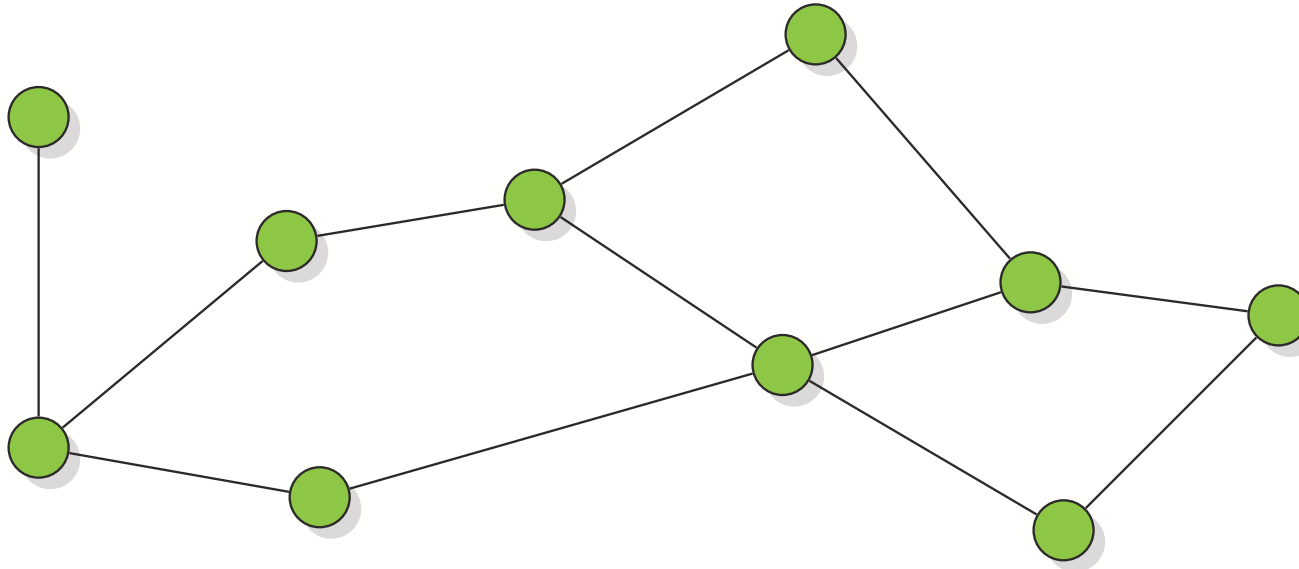

How to Choose a Leader?



Proof-of-Work



Proof-of-Work

Block

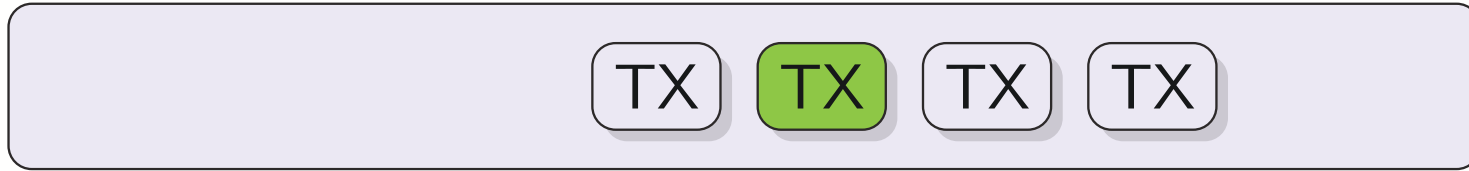

Proof-of-Work

Block

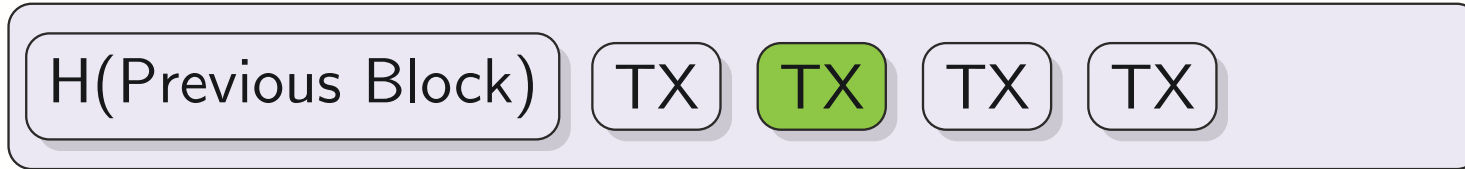

Proof-of-Work

Block

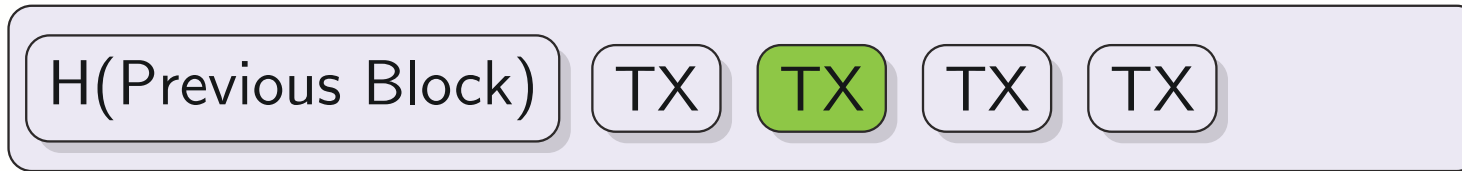

- ▶ $H(\text{Block}) \rightarrow \text{fd2e2055f117bfa261b5a6c7e11df367}\dots$

Proof-of-Work

Block

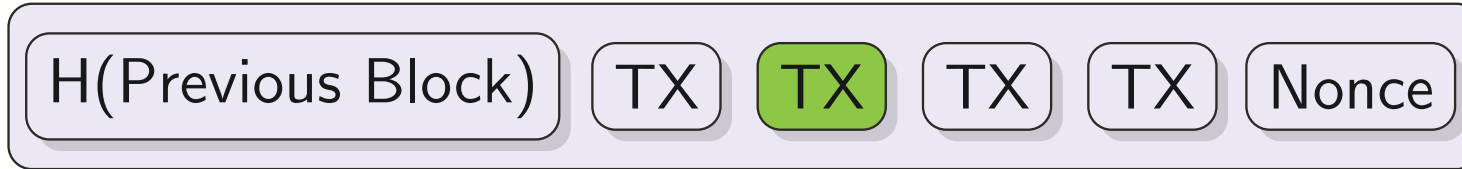

- ▶ $H(\text{Block}|0) \rightarrow 094d66aa7c844a9dbb516a41259b5877\dots$

Proof-of-Work

Block

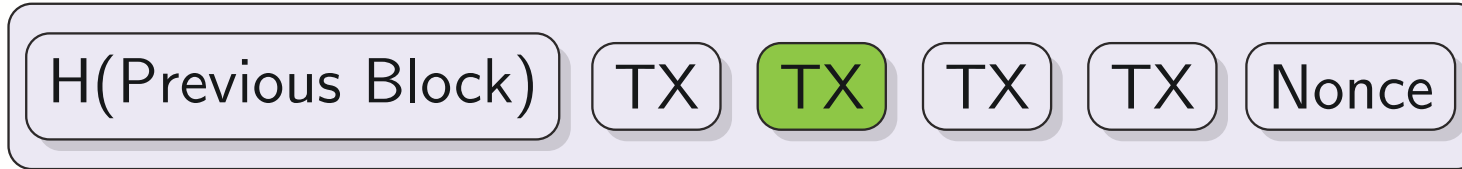

- ▶ $H(\text{Block}|0) \rightarrow 094d66aa7c844a9dbb516a41259b5877\dots$
- ▶ $H(\text{Block}|1) \rightarrow f2496854af8bf989171587a9259f634f\dots$

Proof-of-Work

Block

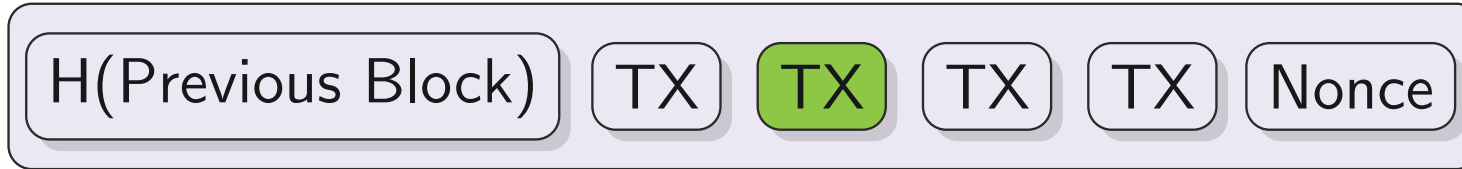

- ▶ $H(\text{Block}|0) \rightarrow 094d66aa7c844a9dbb516a41259b5877\dots$
- ▶ $H(\text{Block}|1) \rightarrow f2496854af8bf989171587a9259f634f\dots$
- ▶ $H(\text{Block}|2) \rightarrow aec87c0ca2e5eb3f23111092f1089ada\dots$

Proof-of-Work

Block

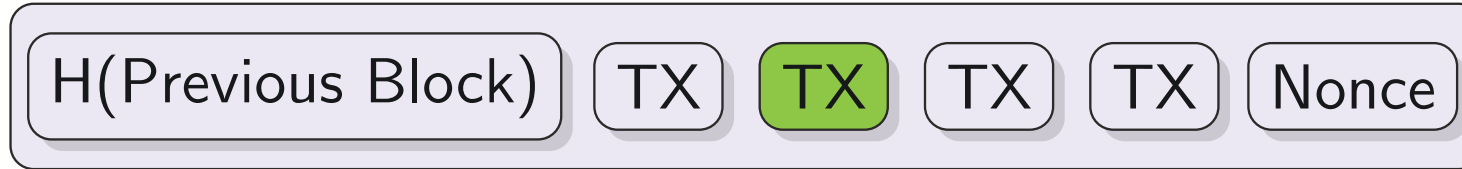

- ▶ $H(\text{Block}|0) \rightarrow 094d66aa7c844a9dbb516a41259b5877\dots$
- ▶ $H(\text{Block}|1) \rightarrow f2496854af8bf989171587a9259f634f\dots$
- ▶ $H(\text{Block}|2) \rightarrow aec87c0ca2e5eb3f23111092f1089ada\dots$
- ▶ $H(\text{Block}|3) \rightarrow 777f75b2a8ecfdc8026c236fc1d2ffa0\dots$
- ▶ \vdots
- ▶ $H(\text{Block}|961127) \rightarrow 0000014823419622d4c133672a7d657e\dots$

The Blockchain

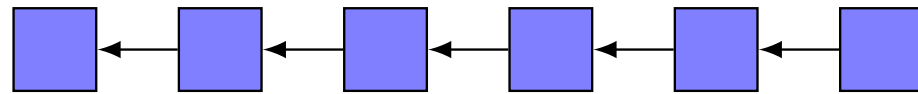

The Blockchain

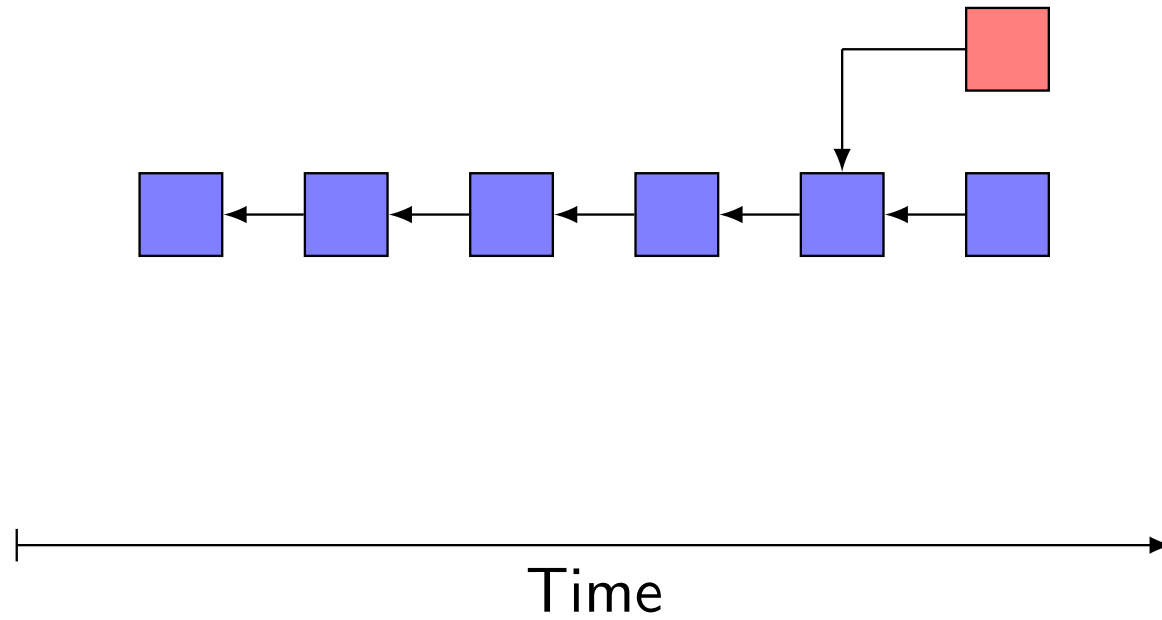

Is Bitcoin stable?

The Blockchain

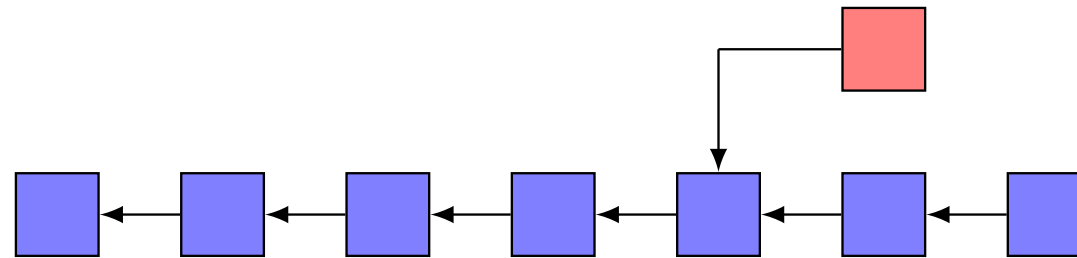

The Blockchain

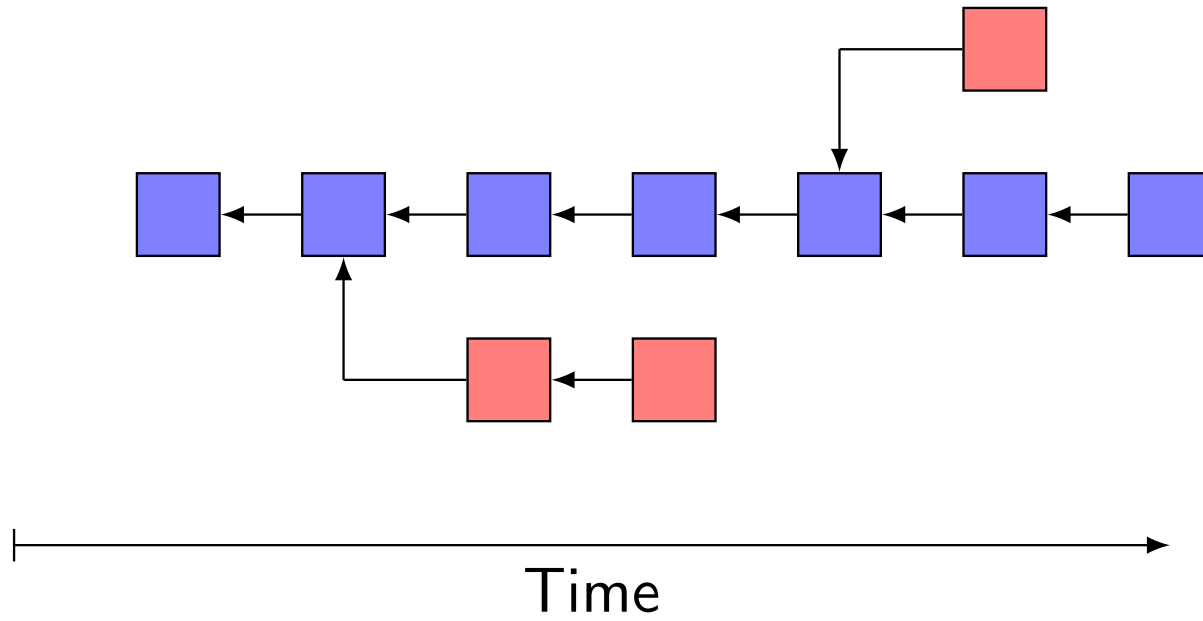

Propagation Speed

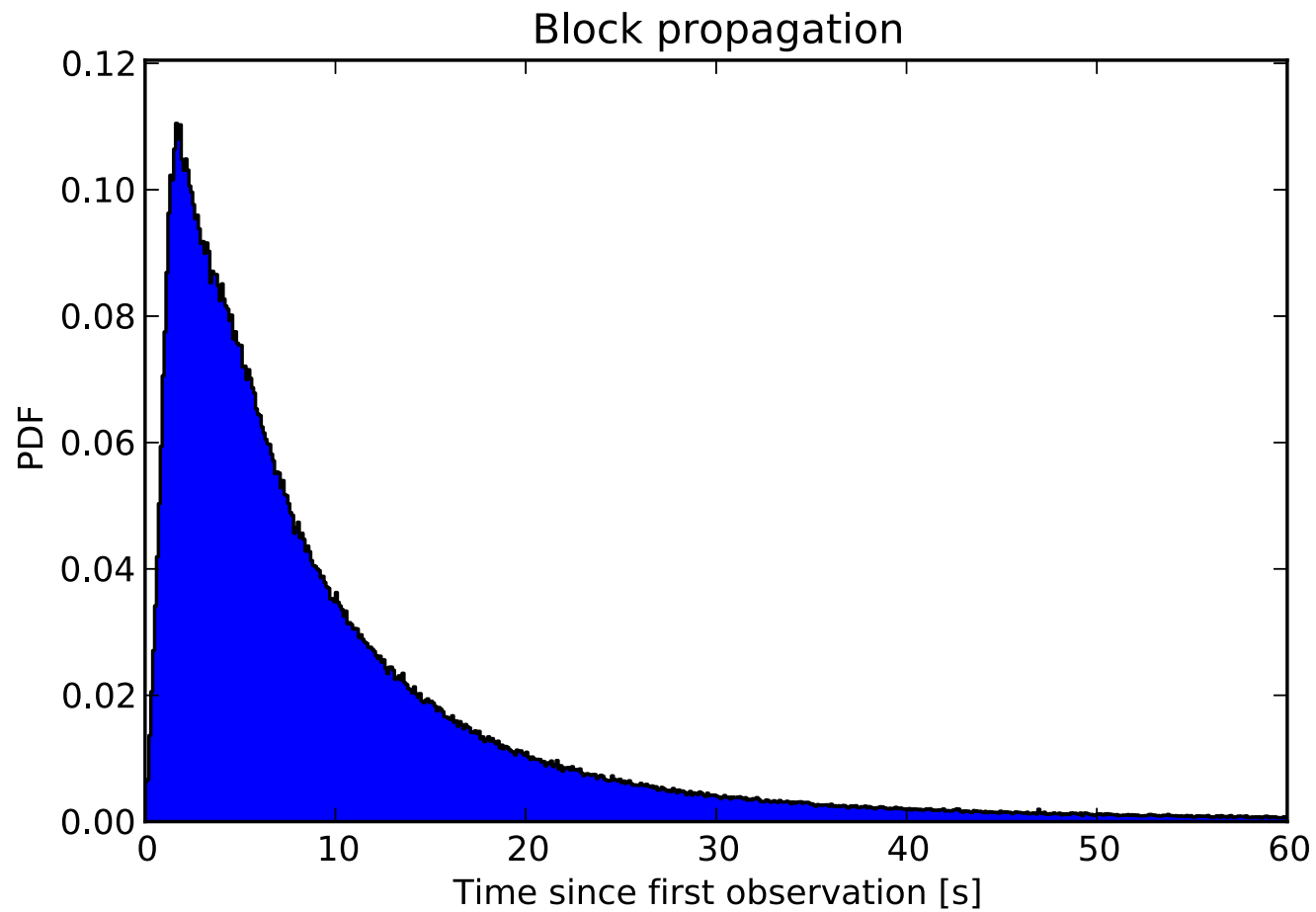

Propagation Speed

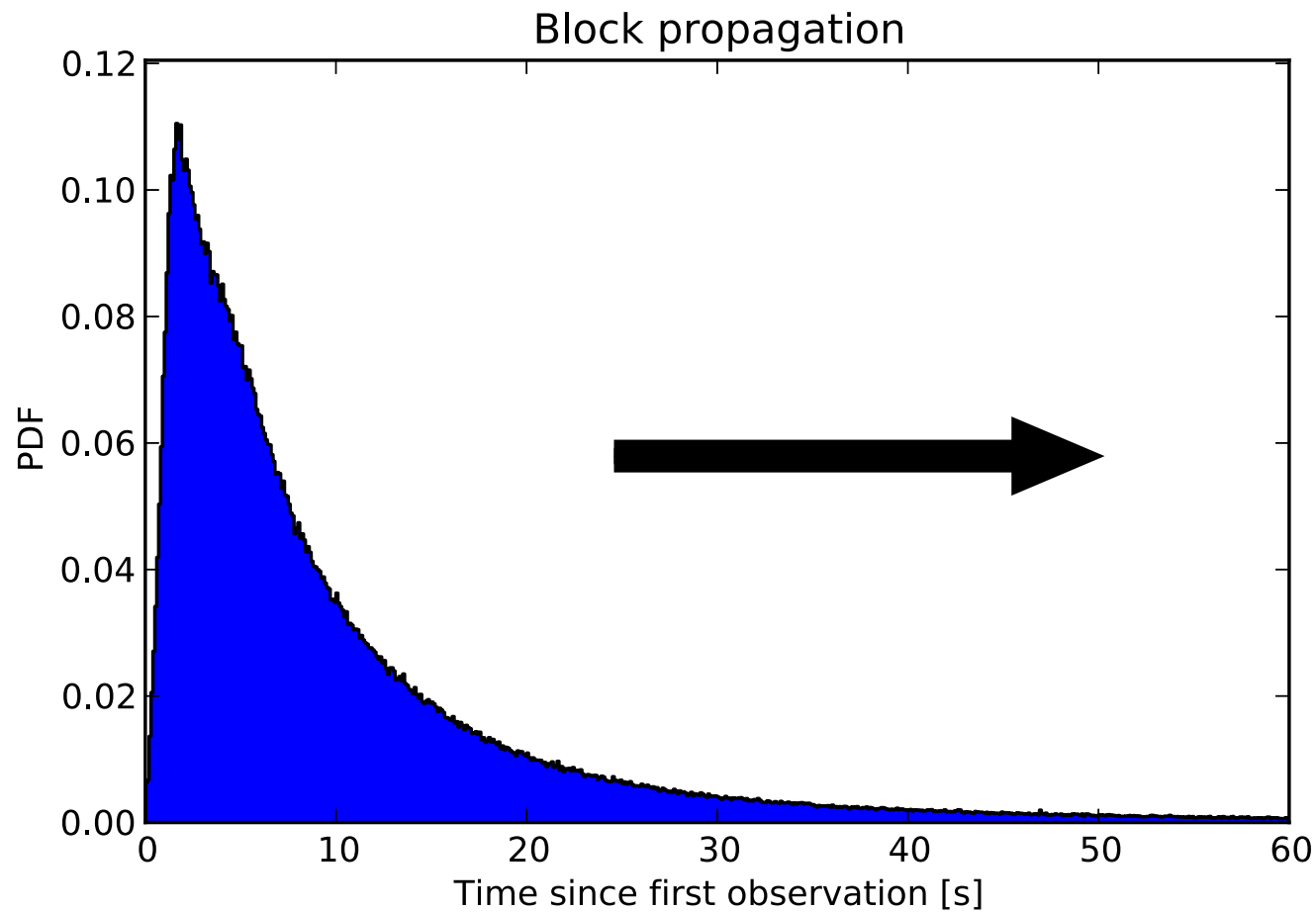

Blockchain Forks

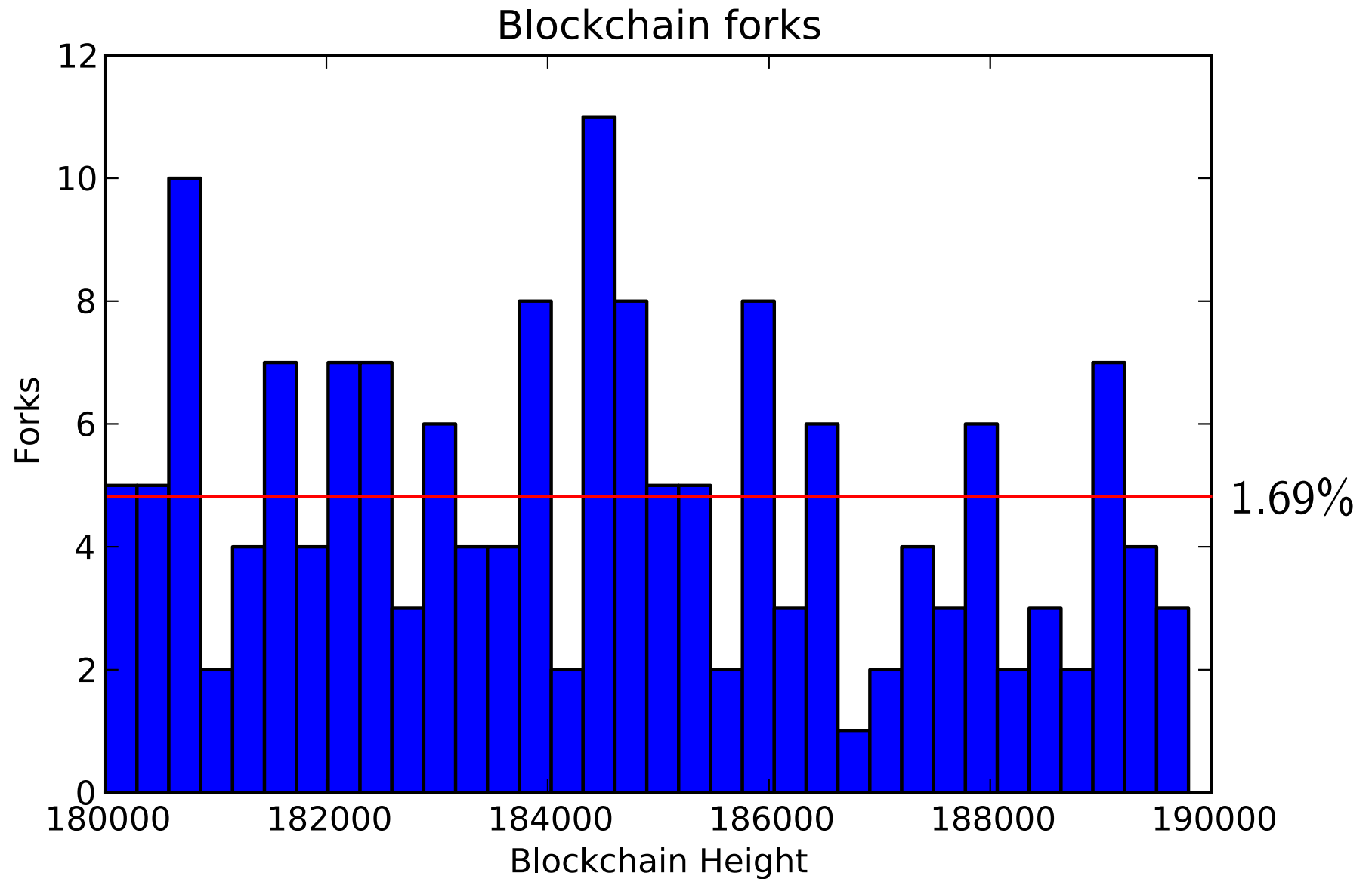

[Decker, W, 2013]

Aside: Mining Evolution

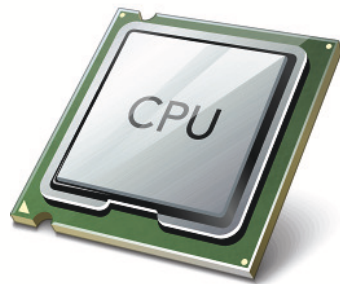
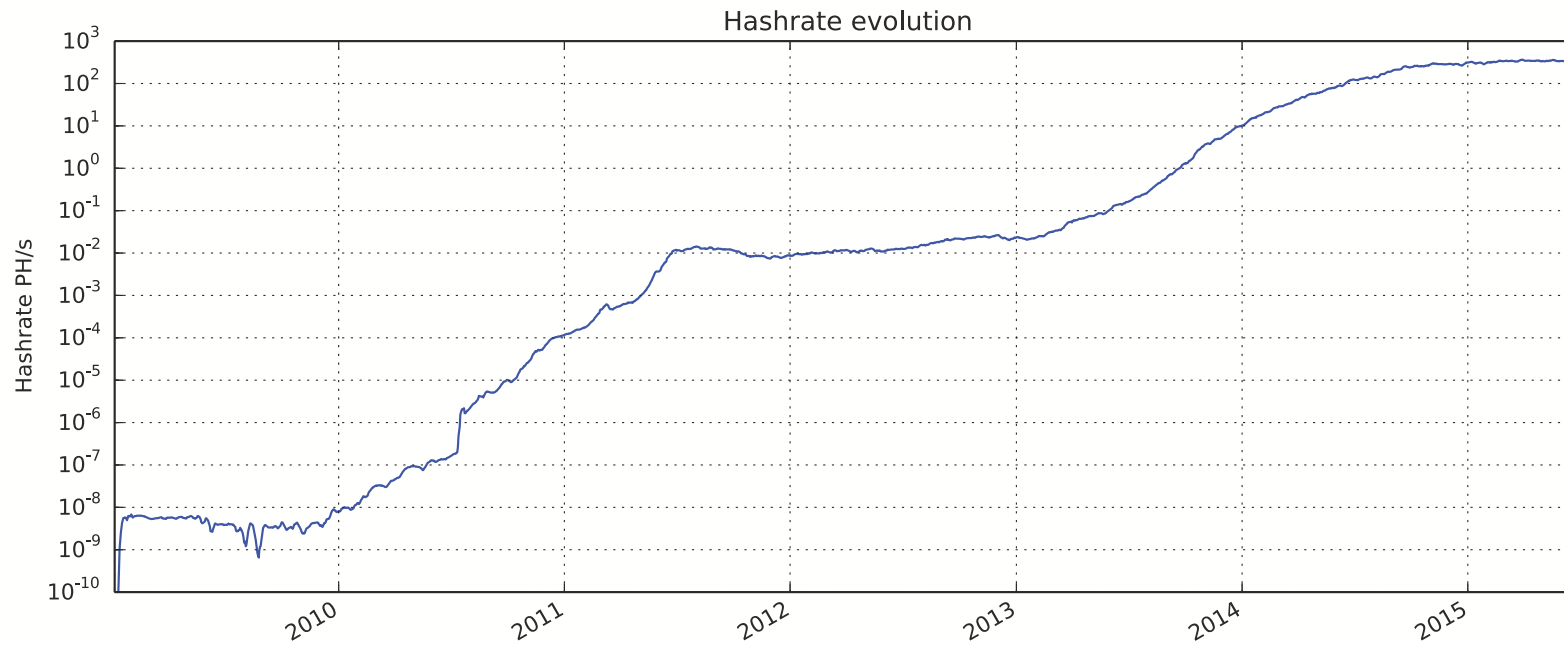

Aside: Mining Evolution

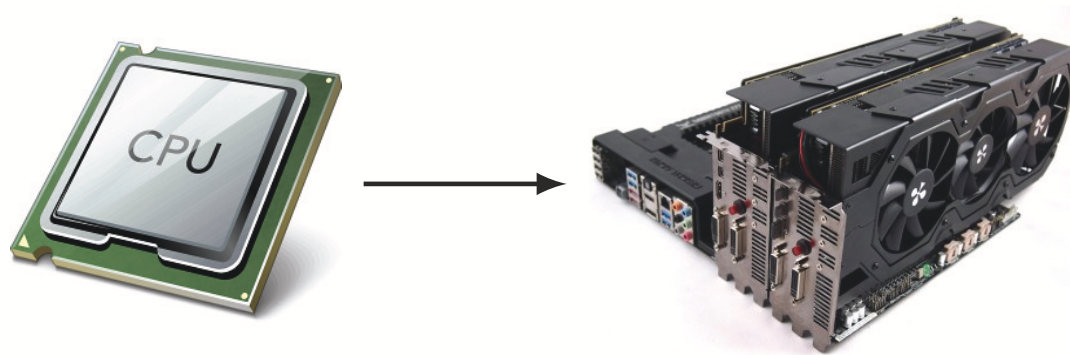
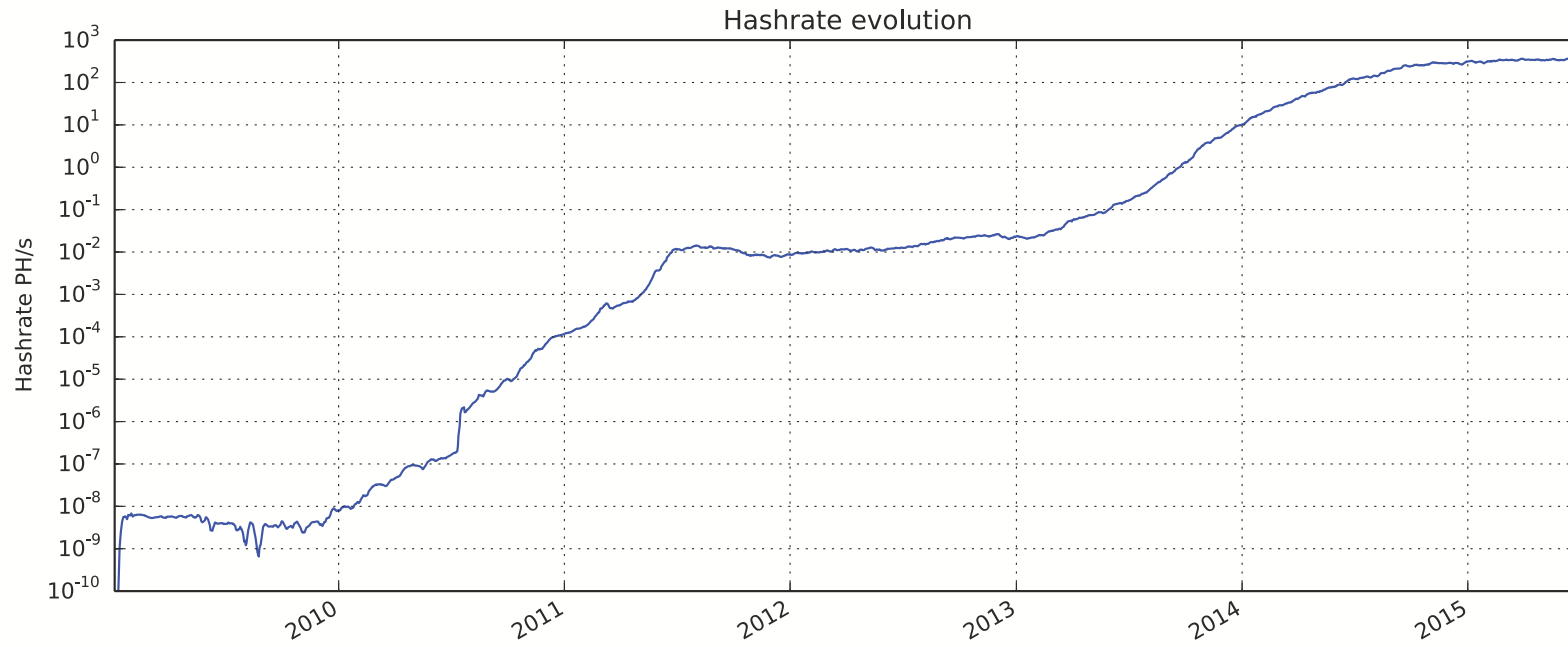

Aside: Mining Evolution

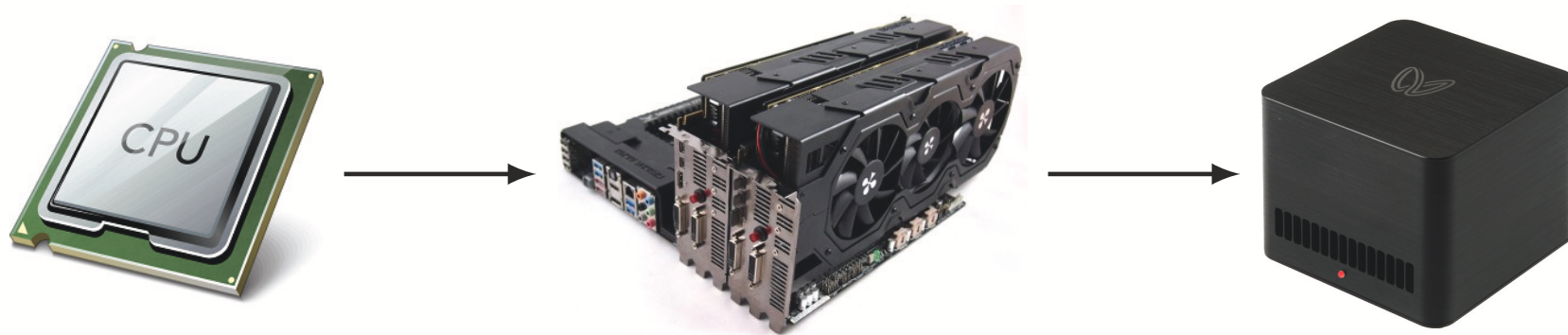
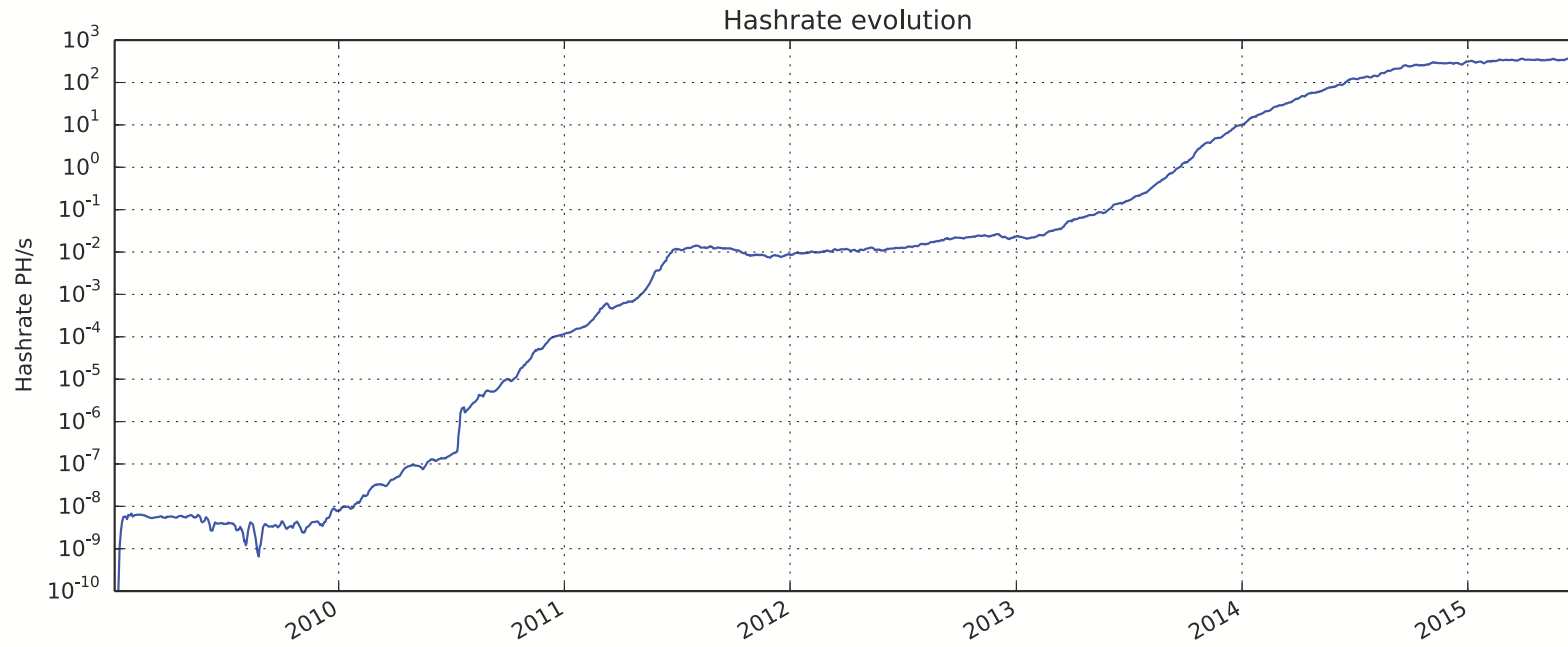

500 MW



Summary

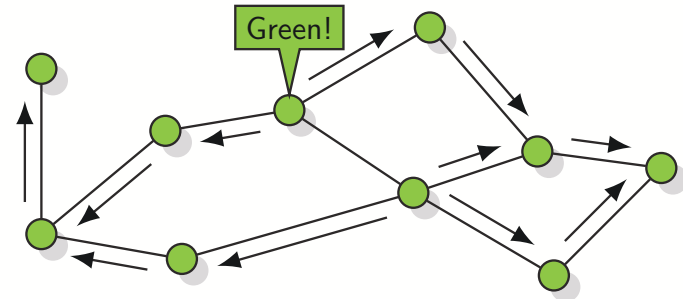
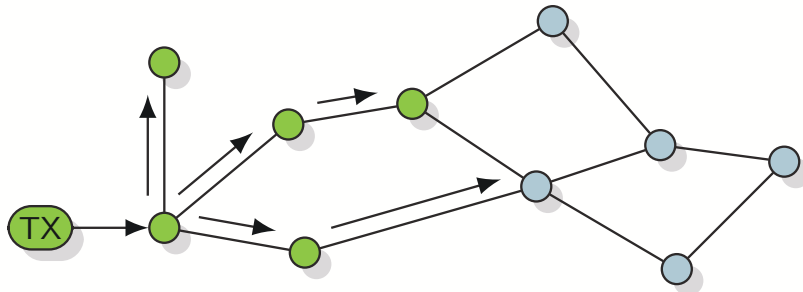

Block

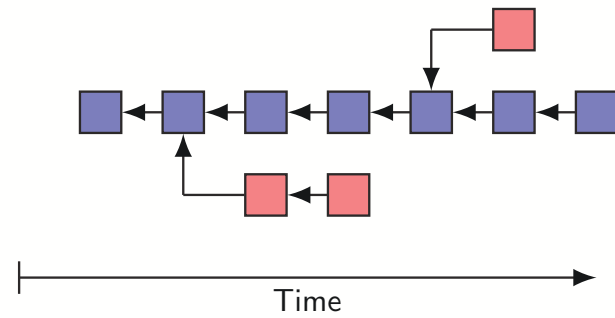
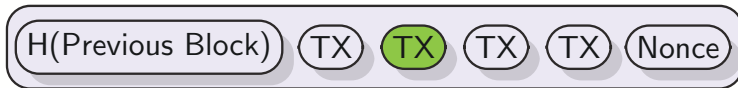

Stories

How to Lose \$500M



Addressing Transaction Malleability: MtGox has detected unusual activity on its Bitcoin wallets and performed investigations during the past weeks.

The MtGox Incident

- ▶ July 2010: First trade on MtGox
- ▶ May 2011: Transaction malleability identified as low priority issue
- ▶ February 7, 2014: MtGox halts withdrawals
- ▶ February 10, 2014: MtGox announces loss of 850,000 bitcoins (620 millio USD) and cites transaction malleability as root cause
- ▶ February 28, 2014: MtGox files for bankruptcy
- ▶ March 7 2014: MtGox finds 200,000 bitcoins
- ▶ August 2015: MtGox CEO is arrested

Signatures

61 af bb 4d e9 f8 b8 74 86 1e

Signatures

00 00 61 af bb 4d e9 f8 b8 74 86 1e

There are multiple ways to serialize a signature:

- ▶ Multiple push operations (1 byte, 2 byte, 4 byte)
- ▶ Non-canonical DER encodings
- ▶ Padding
- ▶ ...

Transaction Malleability Attack

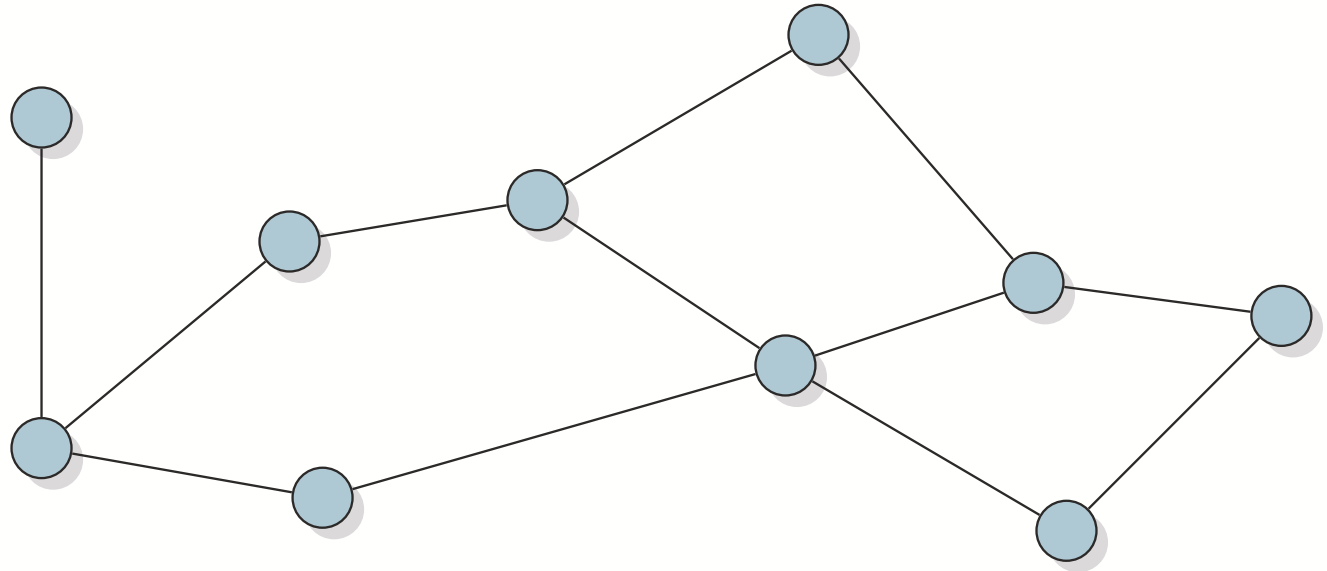

Transaction Malleability Attack

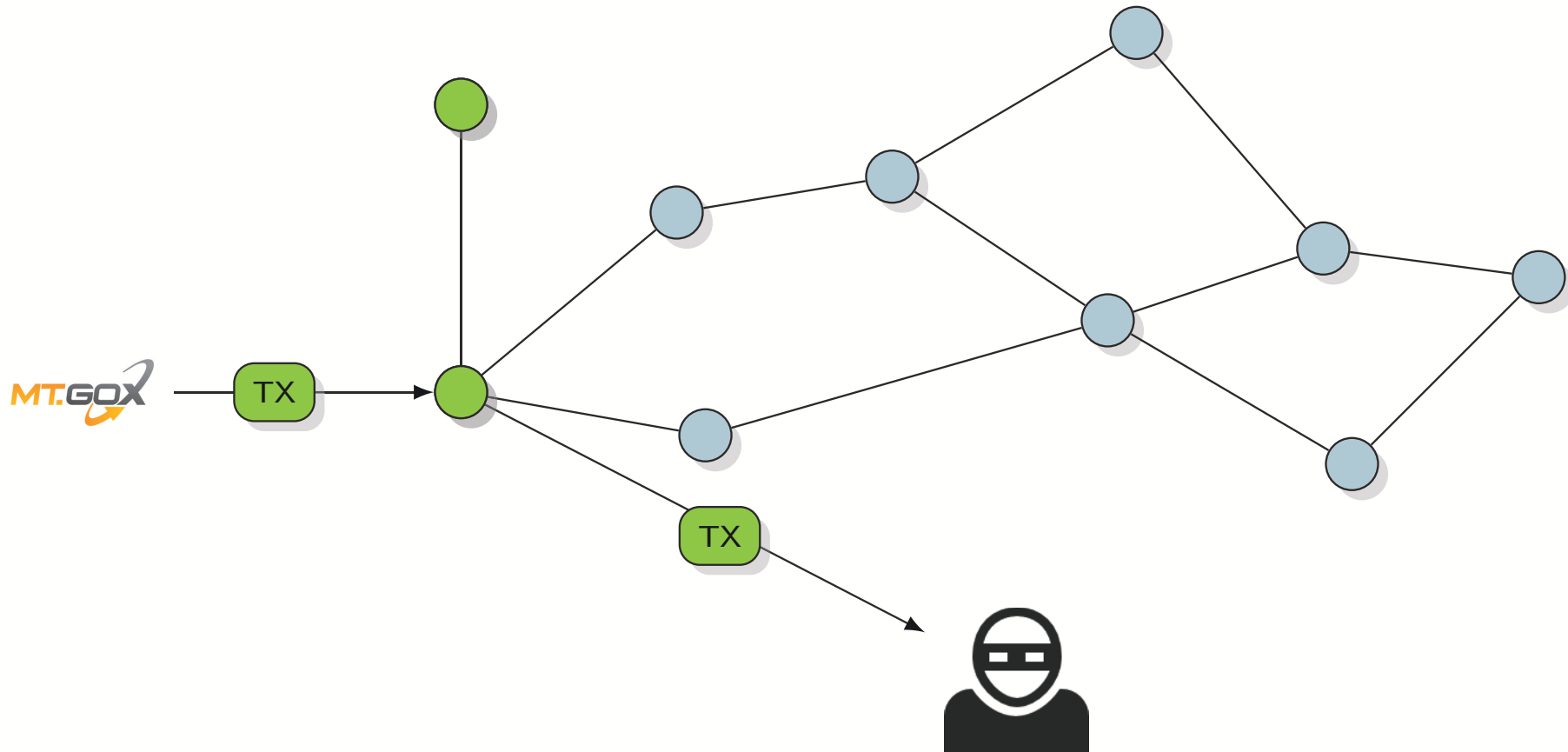

Transaction Malleability Attack

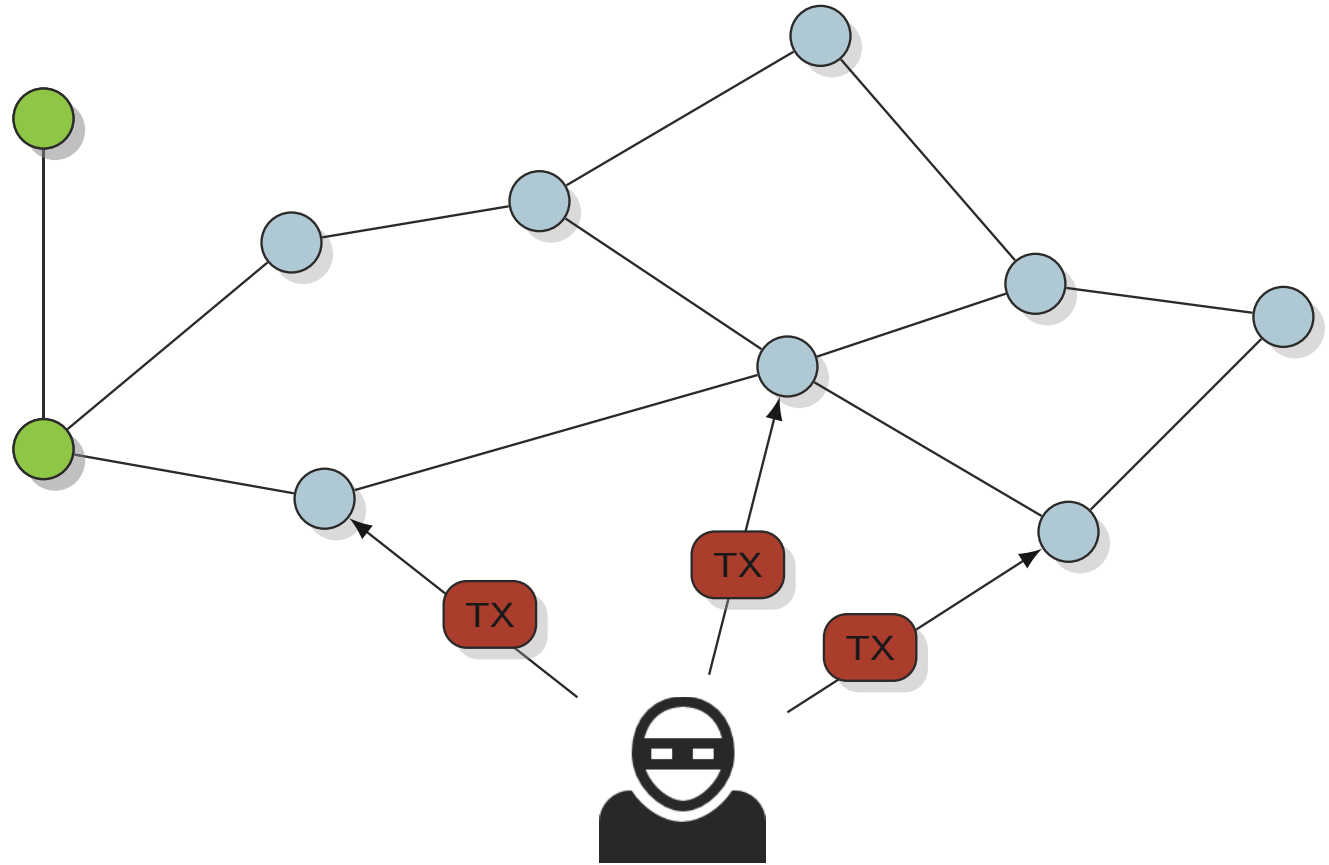

Transaction Malleability Attack

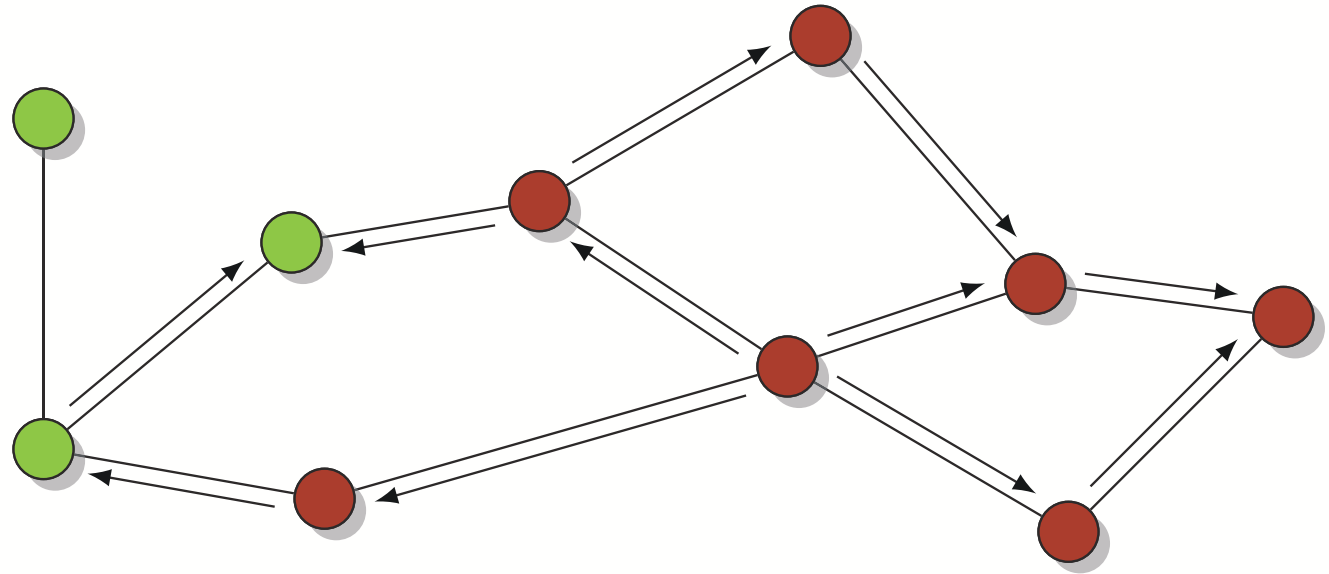

Transaction Malleability Attack

TX?

MT.GOX

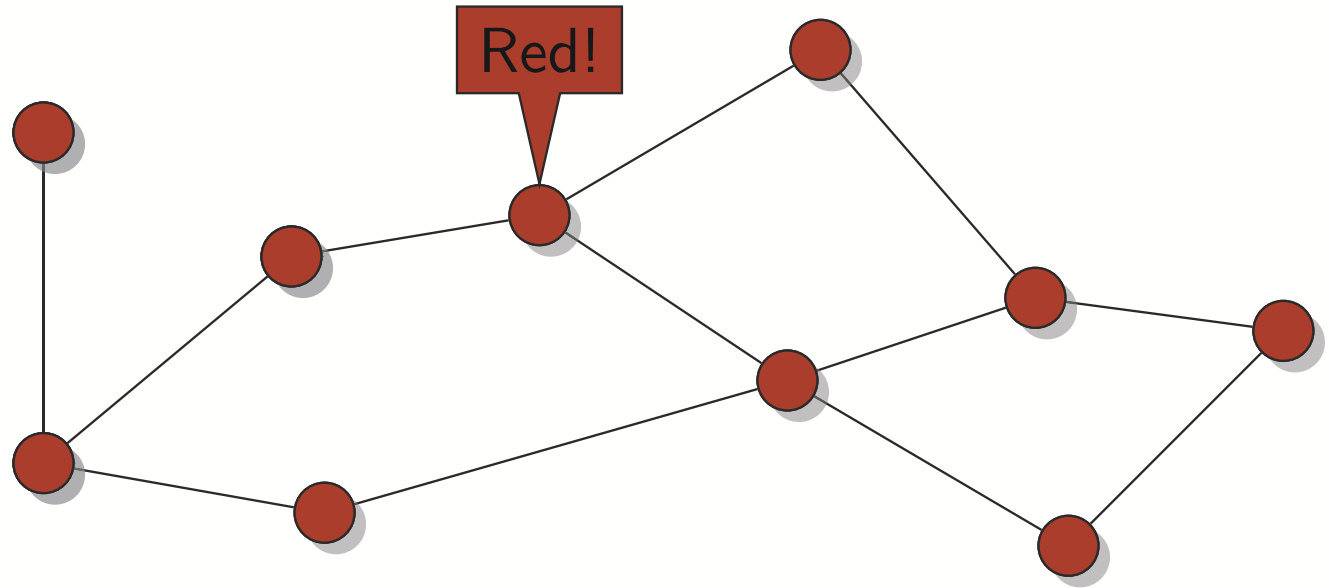

Transaction Malleability Attack

Refund

MT.GOX

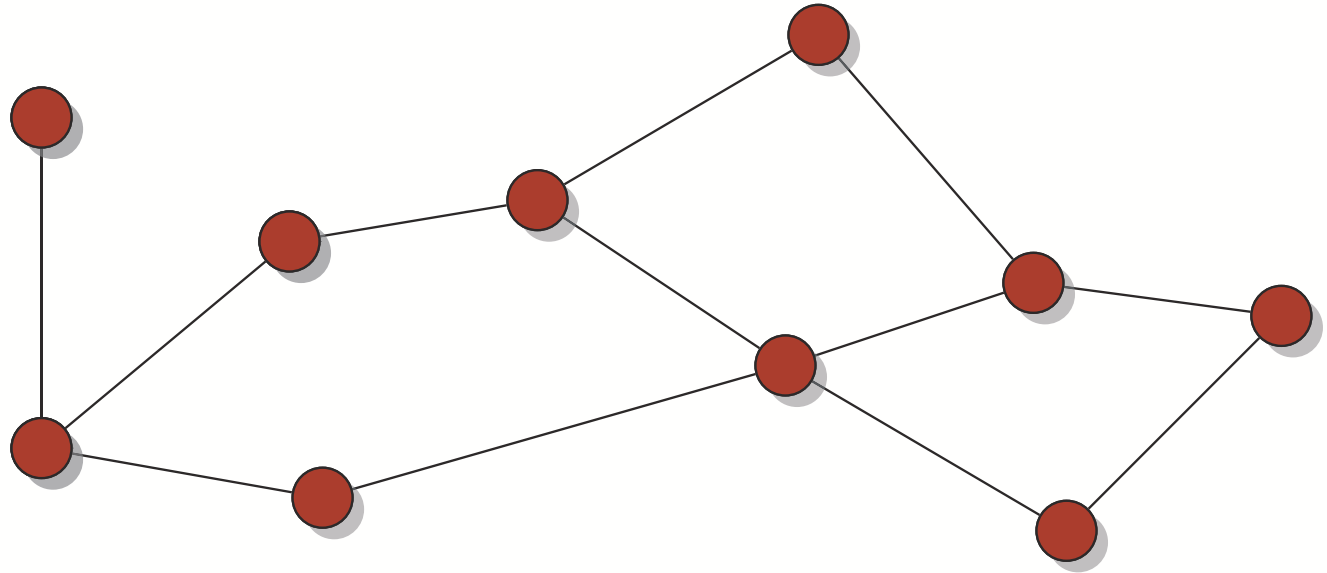

Incident Timeline

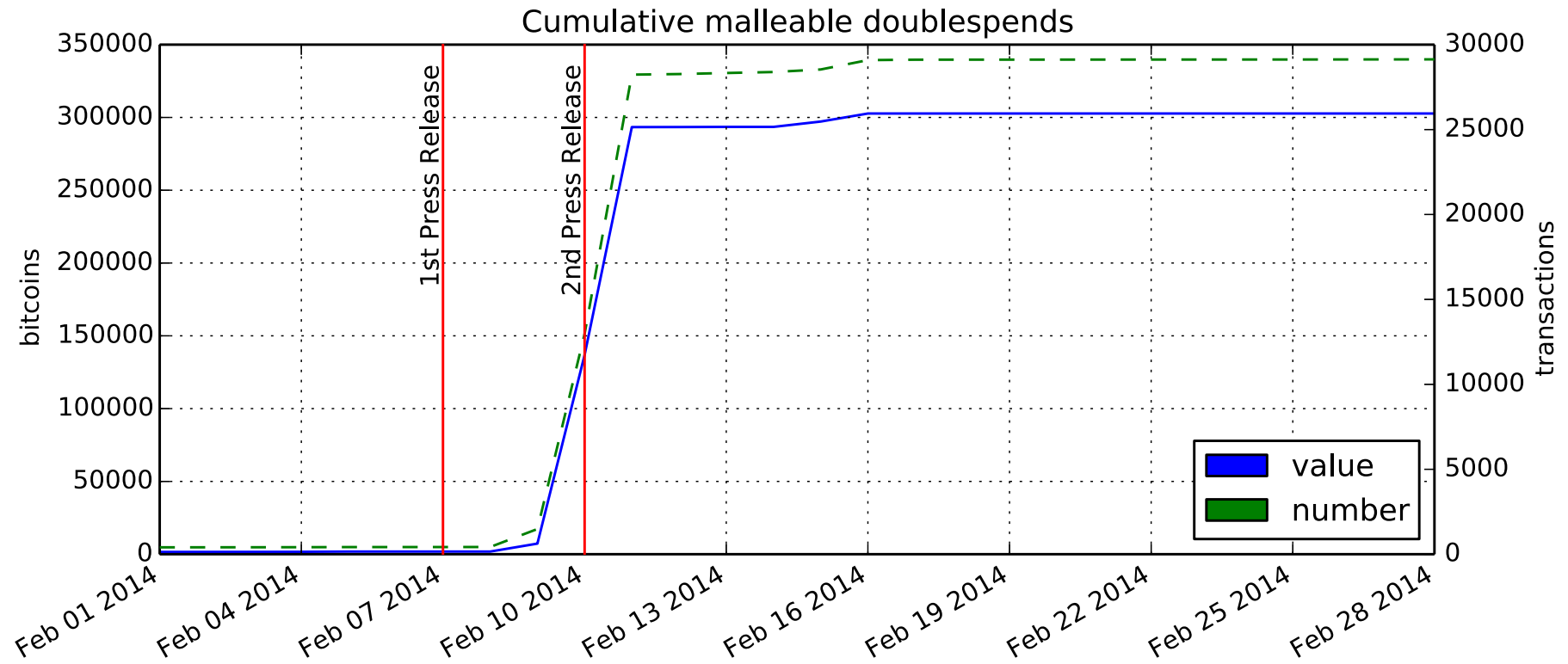

[Decker, W, 2014]

Incident Timeline

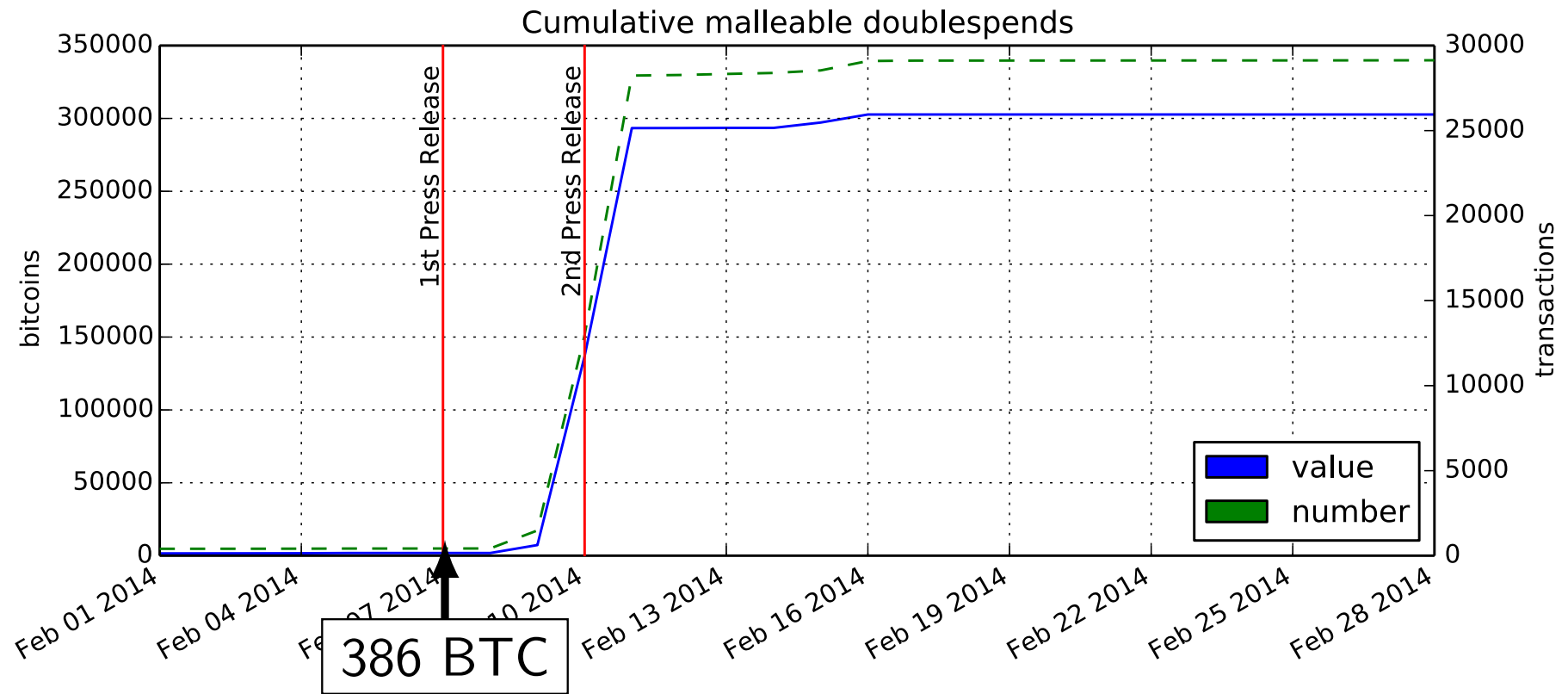

[Decker, W, 2014]

Mt. Gox Seeks Bankruptcy After \$480 Million Bitcoin Loss

By Carter Dougherty and Grace Huang | Feb 28, 2014 8:59 PM GMT+0100 | [95 Comments](#) [Email](#) [Print](#)

Mt. Gox, once the world's largest Bitcoin exchange, filed for bankruptcy in **Japan** saying about \$480 million in Bitcoins belonging to its customers and the firm were missing.

"The company believes there is a high possibility that the Bitcoins were stolen," Mt. Gox said in a statement.

The filing follows three weeks of speculation about the fate of the Tokyo-based exchange, which suspended withdrawals on Feb. 7. Since Bitcoins exist as bits of software, they can be stolen if a hacker gains access to the computers and servers used to run online exchanges, where the virtual currency can be traded for dollars, euros and other currencies.



Mark Karpeles, CEO of Mt. Gox, the world's largest bitcoin exchange, bows for an... [Read More](#)

Is Bitcoin Secure?

Securing Your Bitcoins



[Bamert, Decker, W, 2013]

Does Bitcoin Scale?

The Bitcoin Ecosystem is Growing

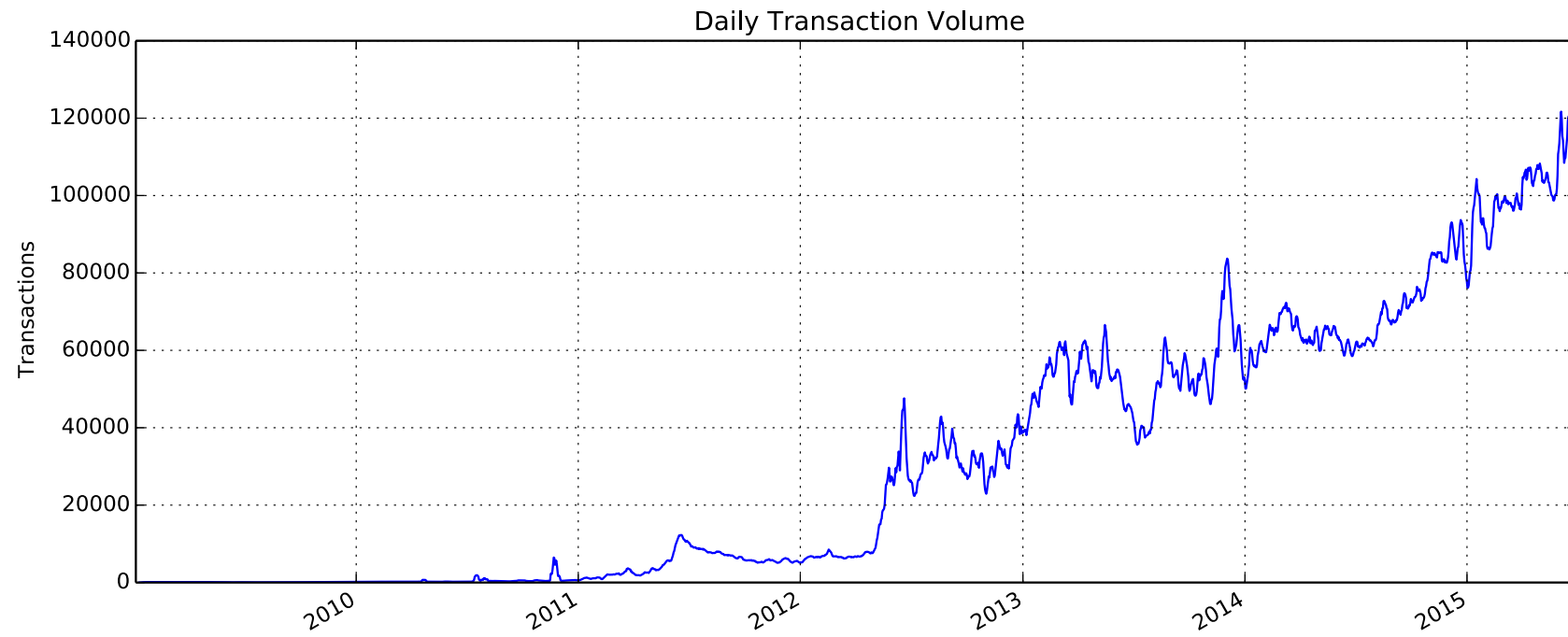

Scalability Limits

- ▶ Disk space: < 500 transactions per second

Scalability Limits

- ▶ Disk space: < 500 transactions per second
- ▶ Processing power: < 200 transactions per second

Scalability Limits

- ▶ Disk space: < 500 transactions per second
- ▶ Processing power: < 200 transactions per second
- ▶ Network bandwidth: < 100 transactions per second

Scalability Limits

- ▶ Disk space: < 500 transactions per second
- ▶ Processing power: < 200 transactions per second
- ▶ Network bandwidth: < 100 transactions per second
- ▶ Artificial 1MB limit: < 3 transactions per second

Scalability Limits

- ▶ Disk space: < 500 transactions per second
- ▶ Processing power: < 200 transactions per second
- ▶ Network bandwidth: < 100 transactions per second
- ▶ Artificial 1MB limit: < 3 transactions per second

Today:

- ▶ Bitcoin: 1 transaction per second
- ▶ Credit Cards: $> 10,000$ transactions per second

Payment Network

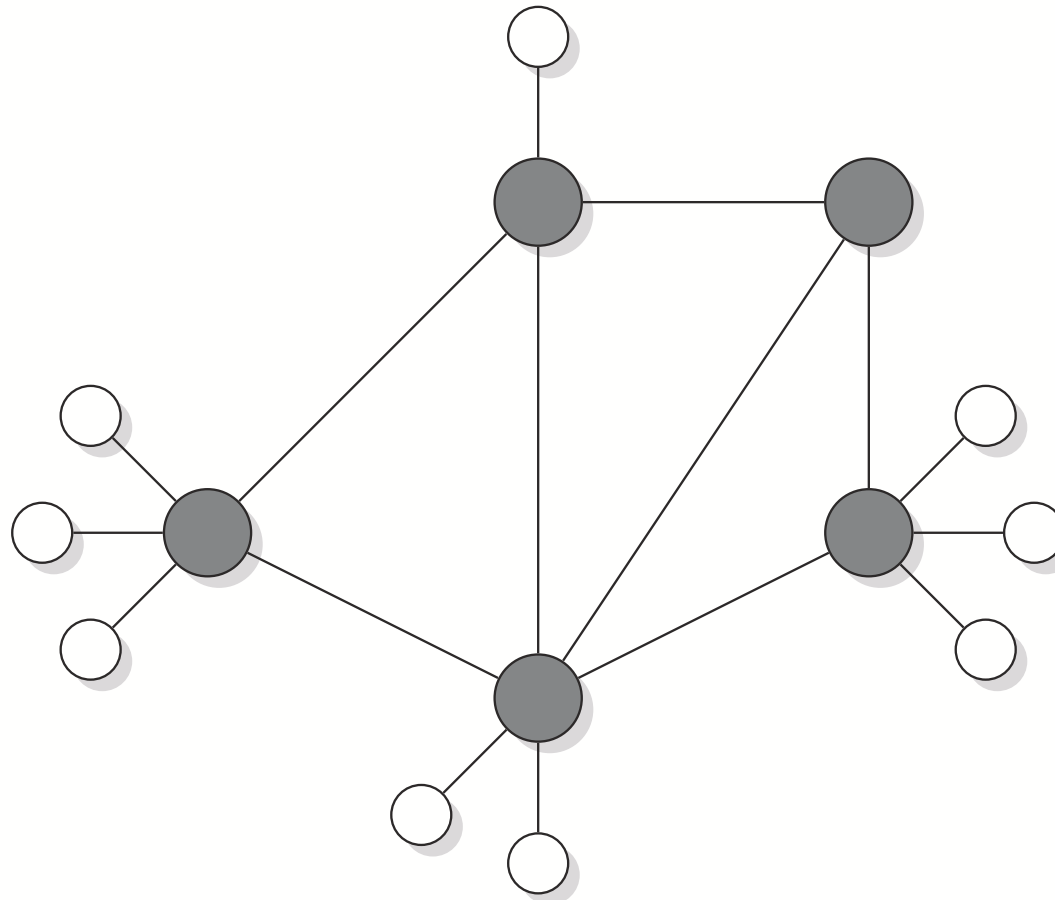

Payment Network

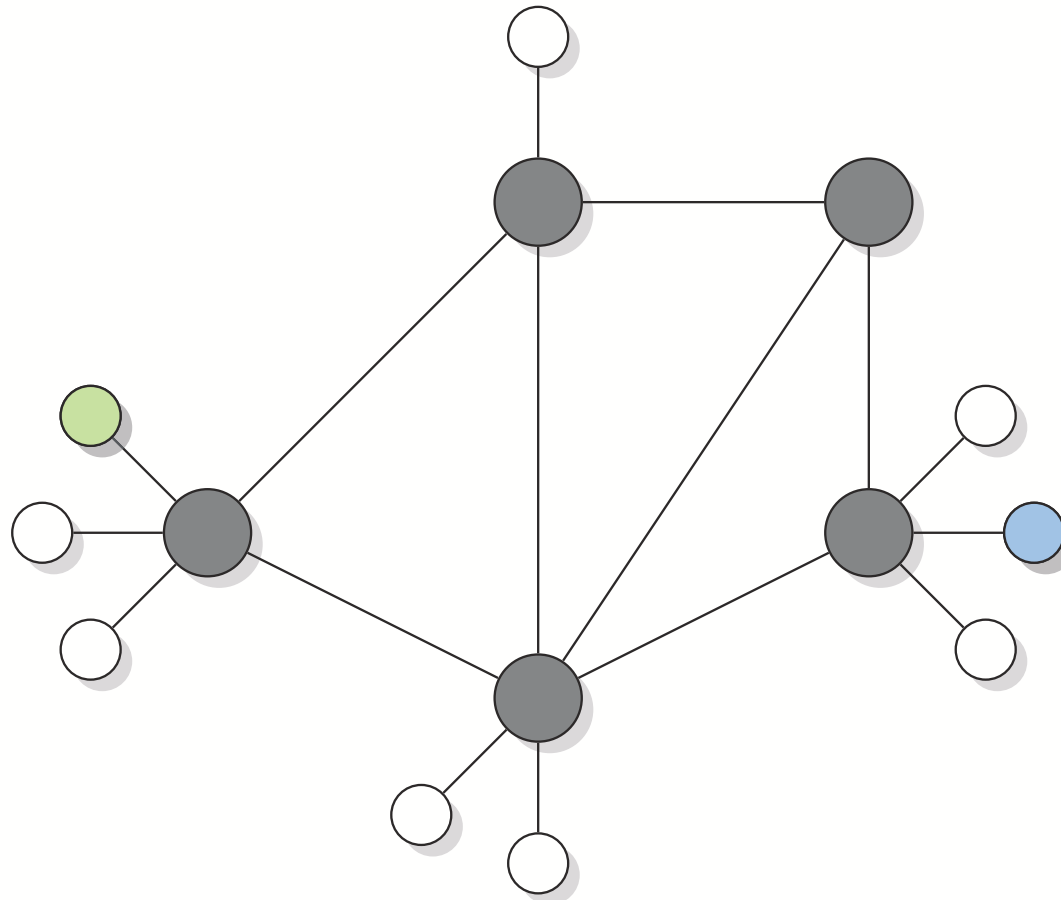

Payment Network

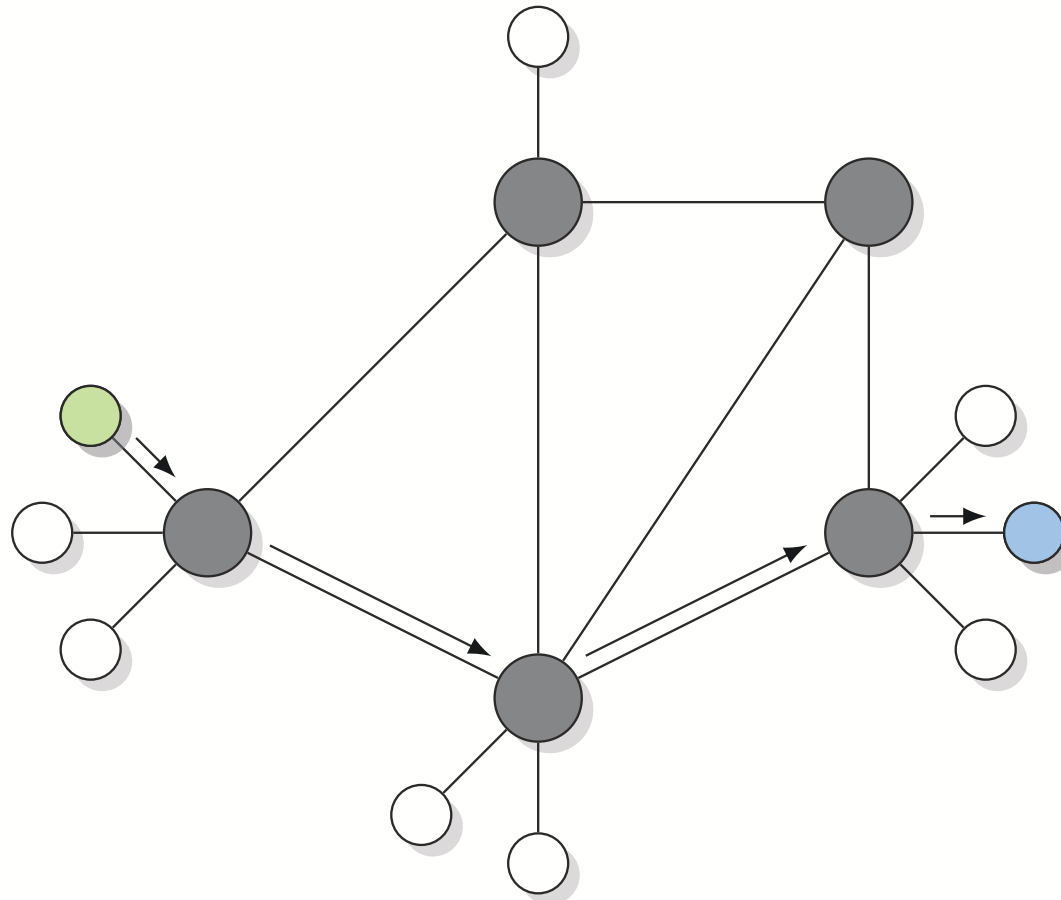

Micropayment Channels

5

Micropayment Channels



Micropayment Channels

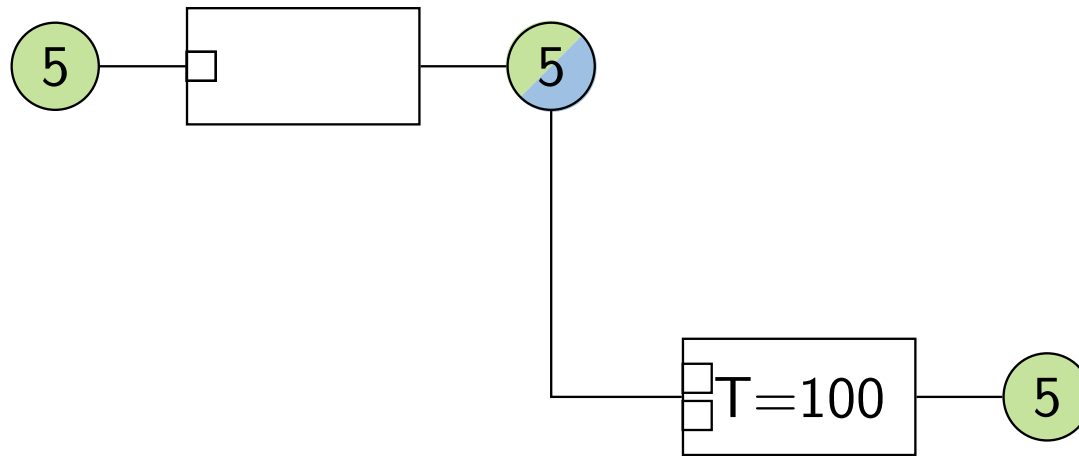

Micropayment Channels

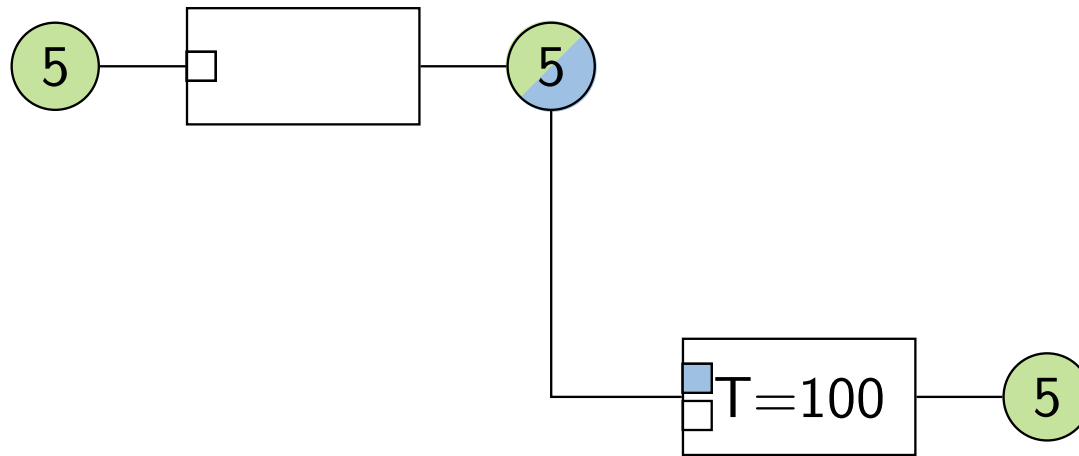

Micropayment Channels

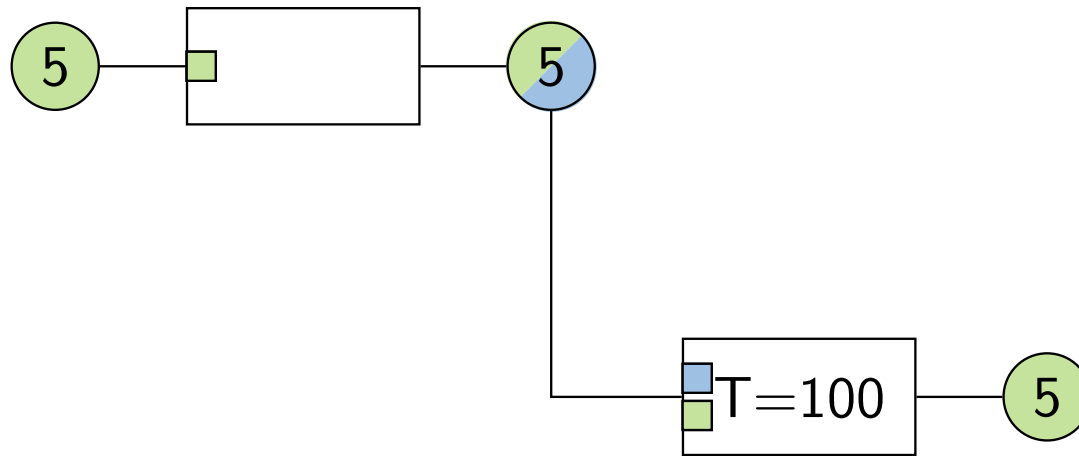

Micropayment Channels

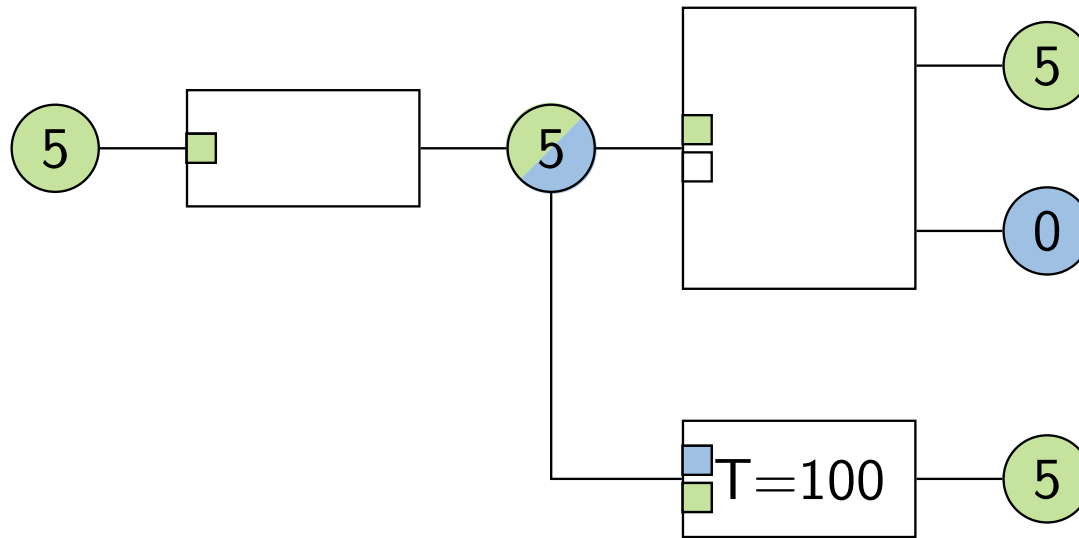

Micropayment Channels

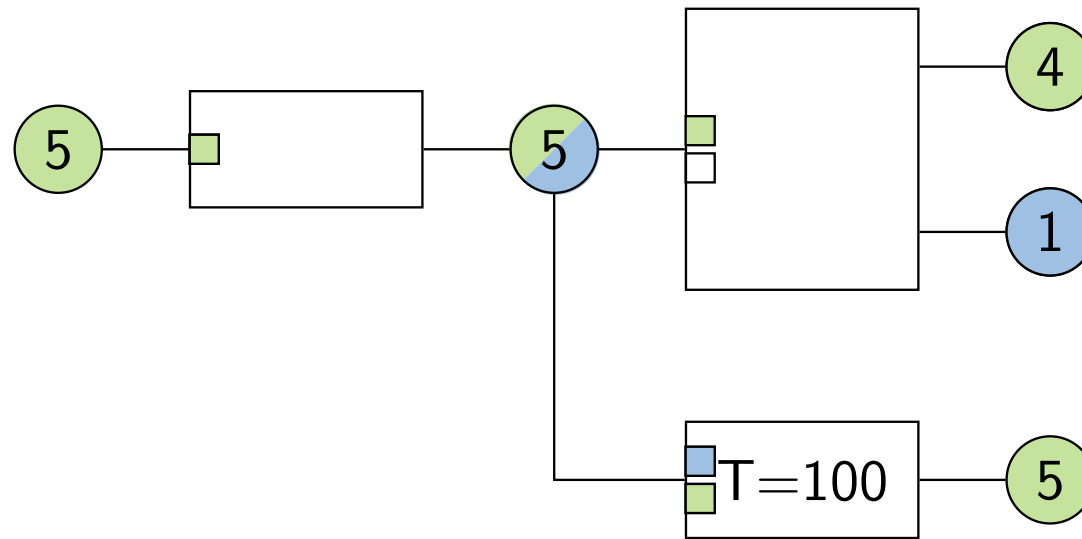

Micropayment Channels

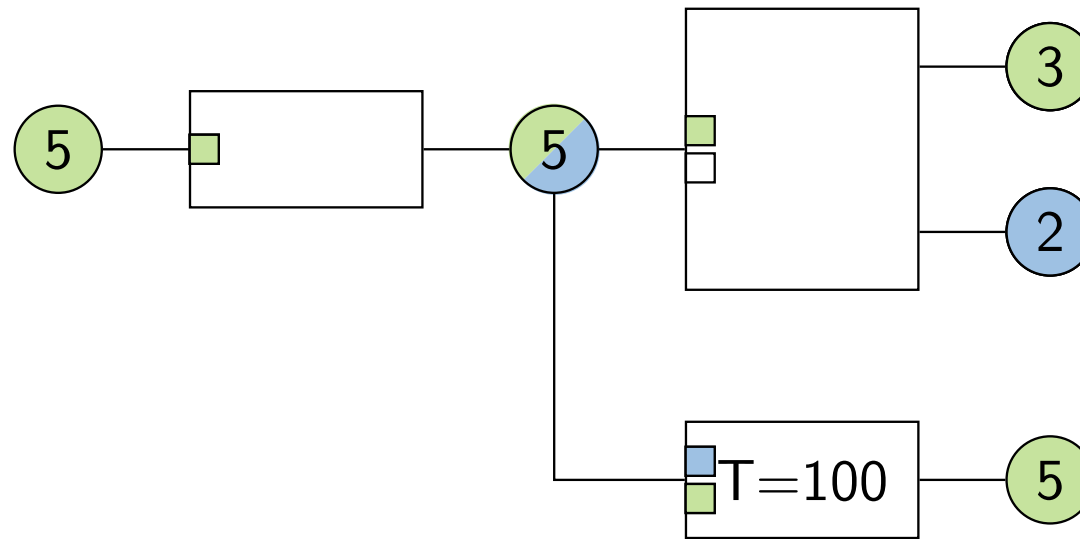

Micropayment Channels

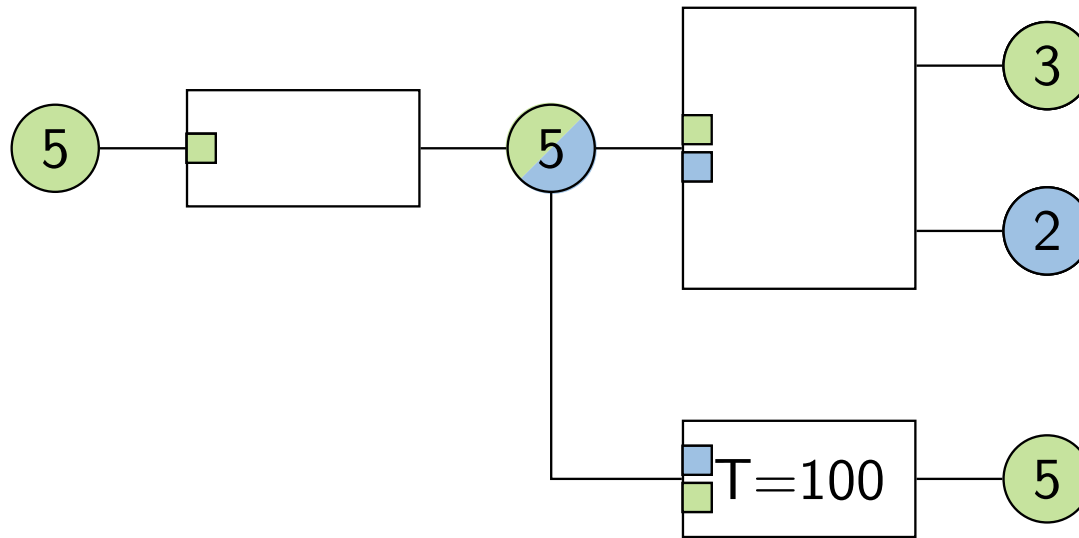

Duplex Micropayment Channels

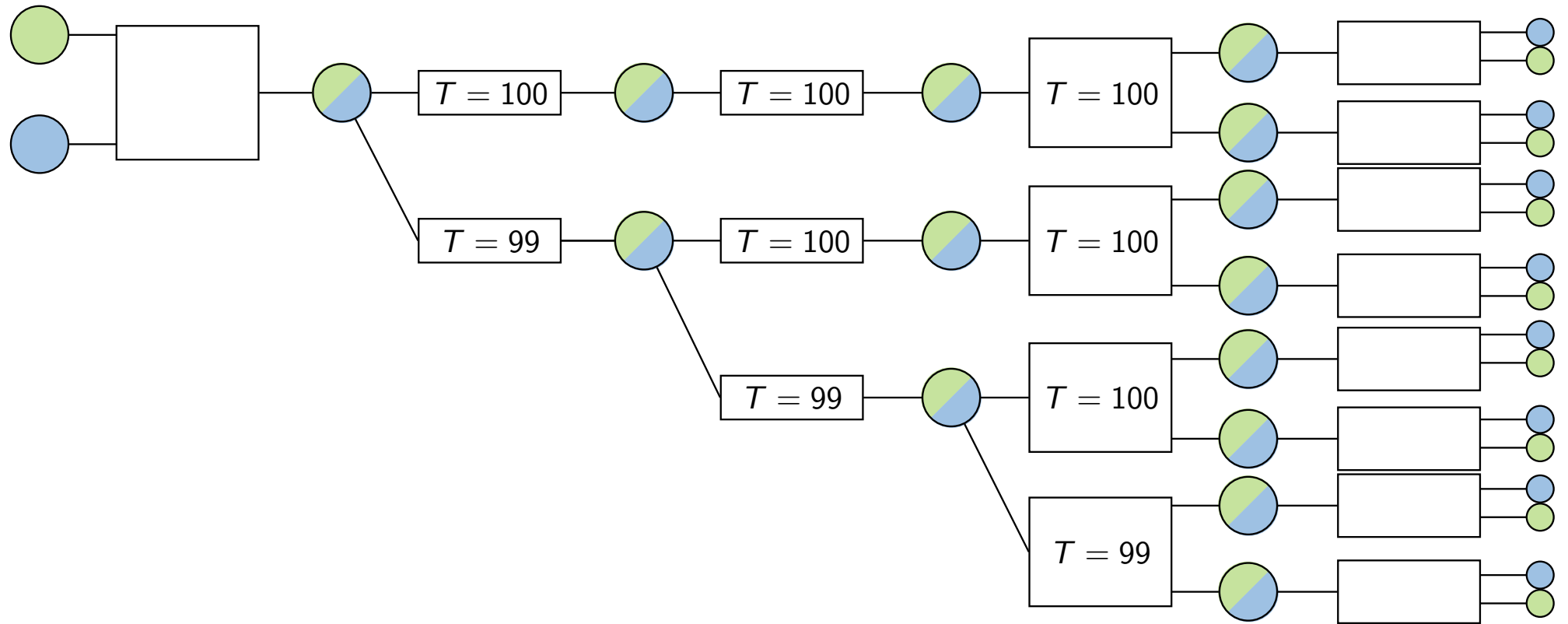

Setup

Invalidation Tree

Micropayment Channels

Summary

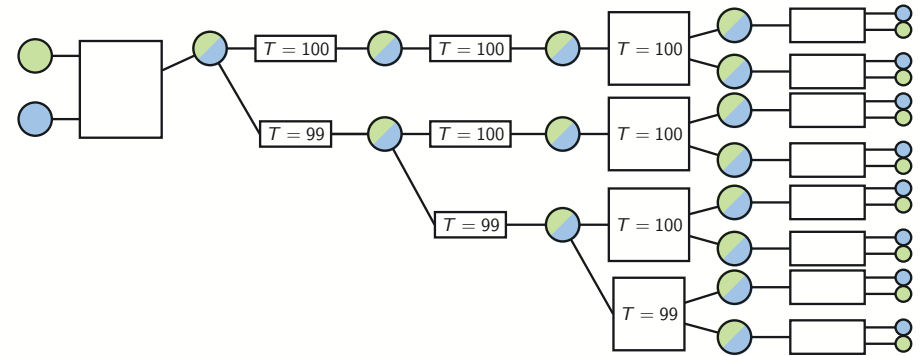
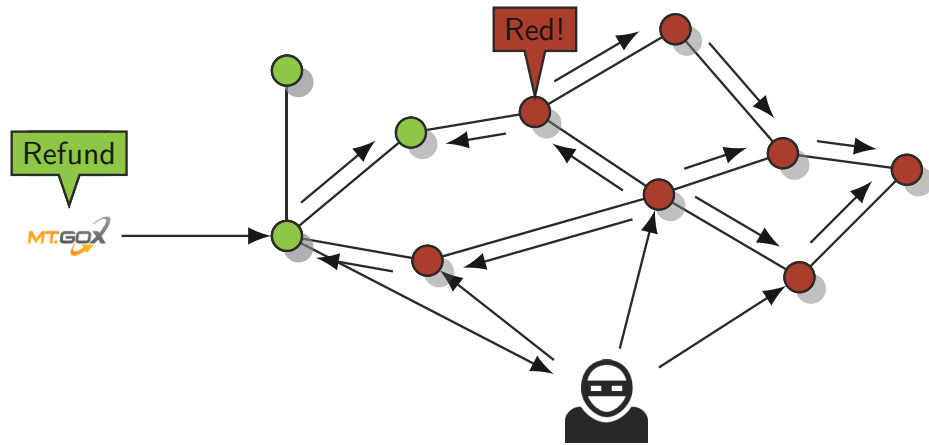

Economy

BTC in USD

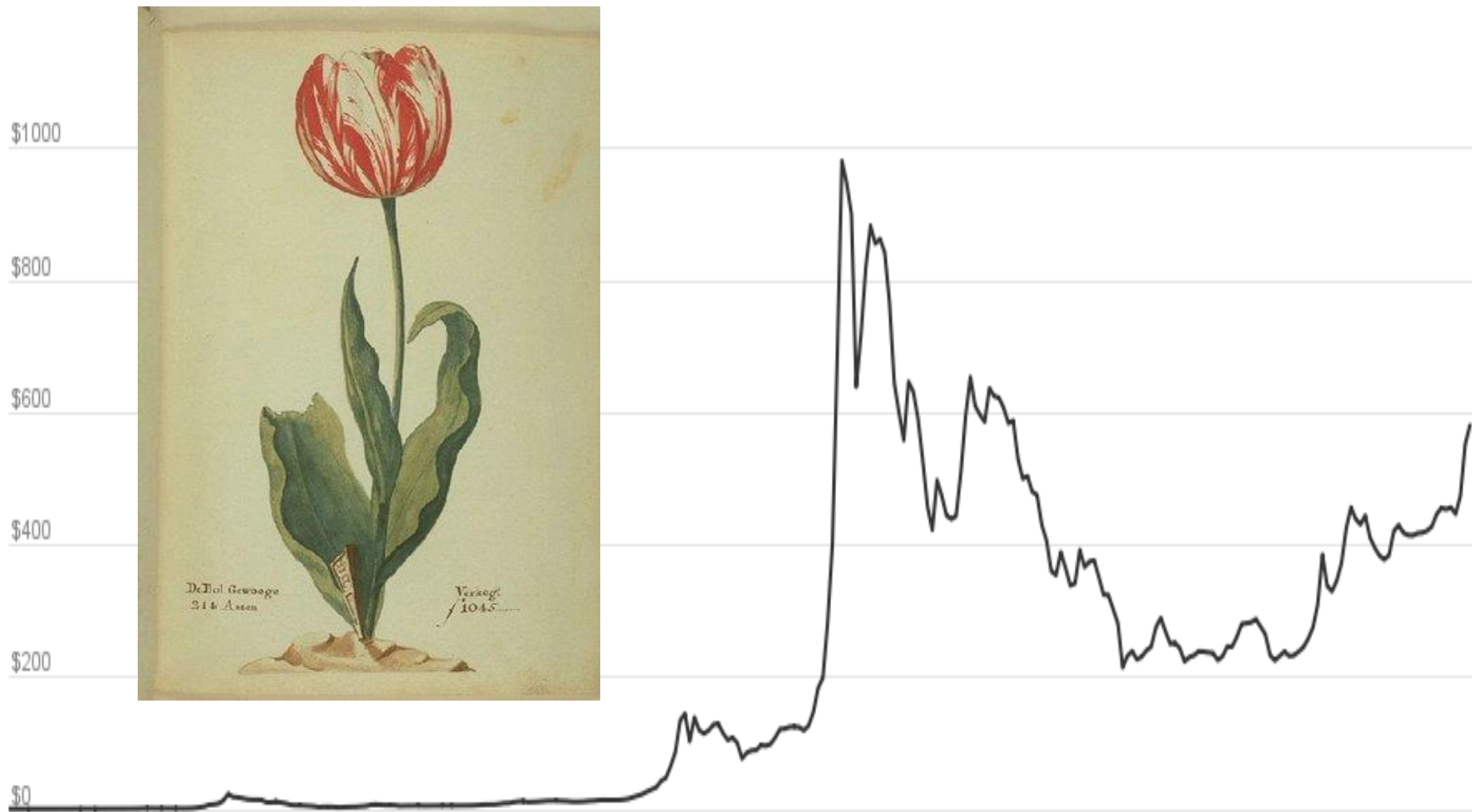

Inflation

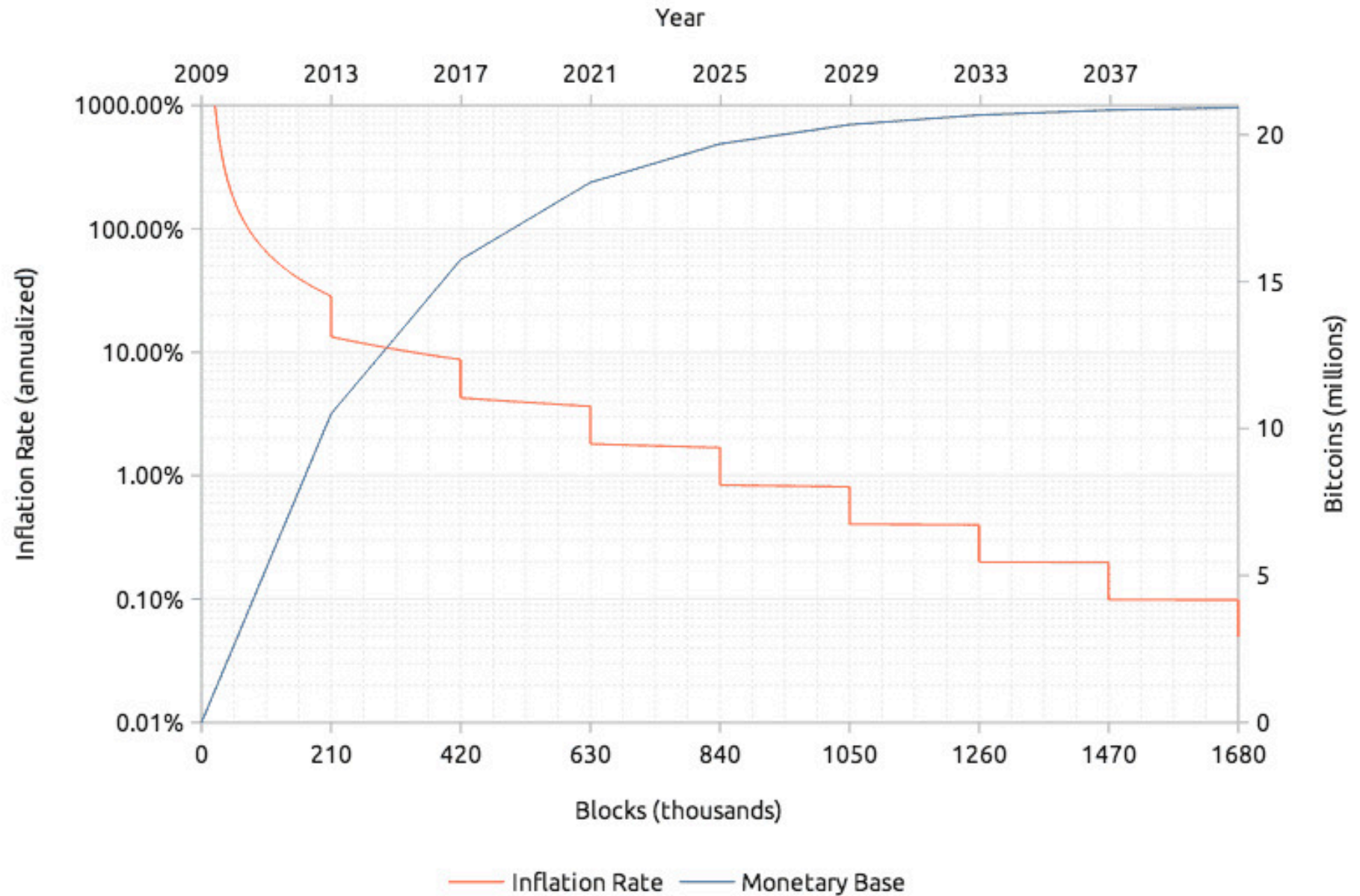

Fungibility

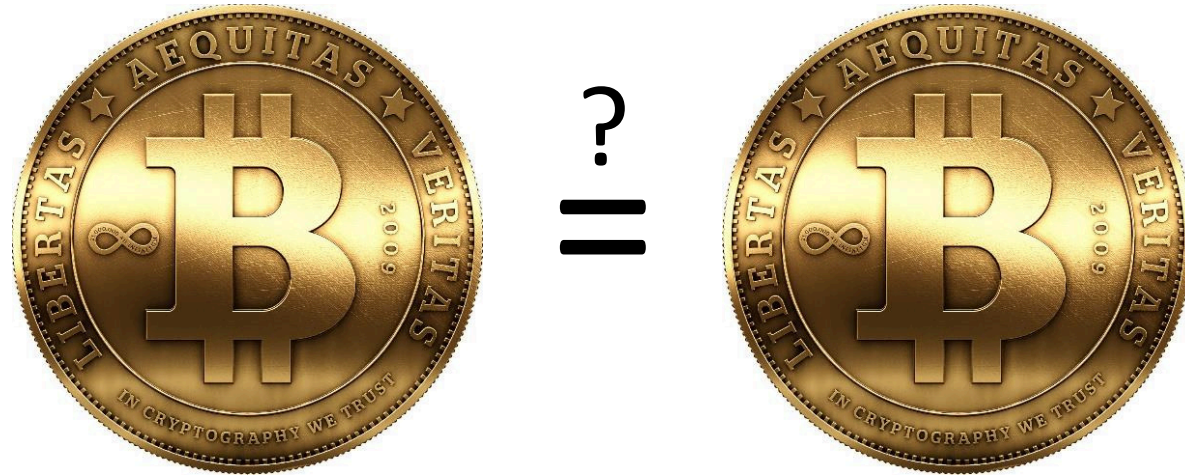

↑
18
↓



Looking to buy an old 50 BTC block. Where to buy? (self.Bitcoin)

submitted 7 months ago by [blockCollector](#)

I'll pay in bitcoin. No FIAT/Alt coin. Willing to pay premium.

Improving Bitcoin?

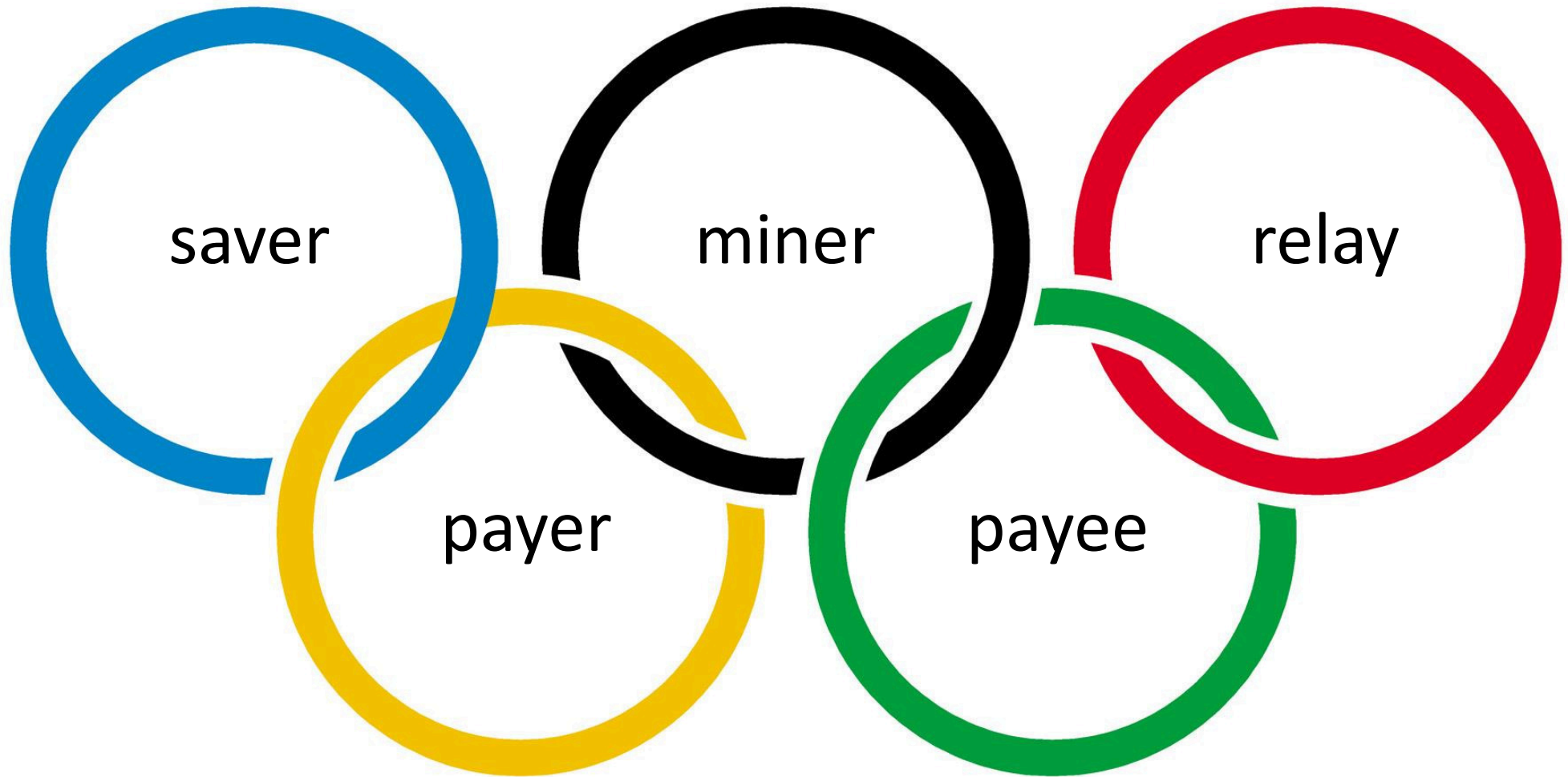

What is Money?

Medium of Exchange



Unit of Account



Store of Value



What is Money?

Medium of Exchange



Unit of Account



Store of Value



Summary

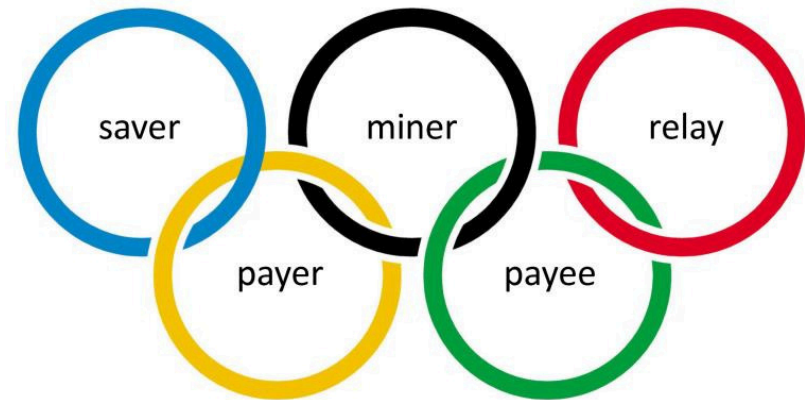
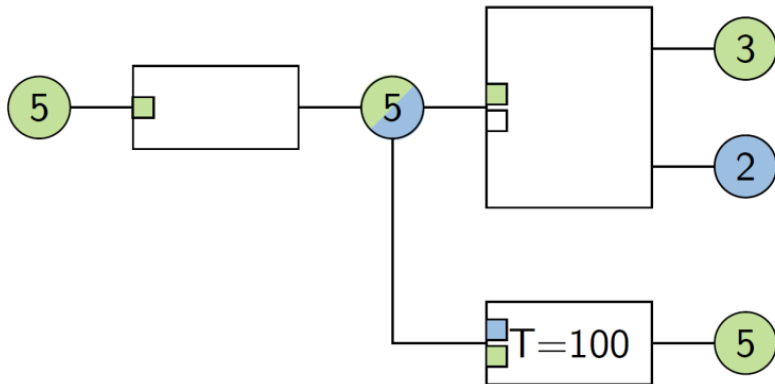
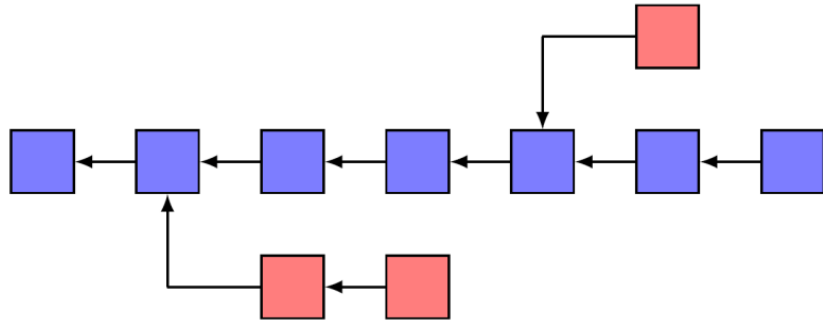

Thank You!

Questions & Comments?



Thanks to my co-author
Christian Decker

www.disco.ethz.ch